

Solahart SunCell PLUS PV Module Installation Manual

Contents

1. Introduction	2
1.1 Purpose	2
1.2 Limitation of Liability	2
2. Codes and Regulations	2
3. Safety	3
3.1 General Safety	3
3.2 Installation Precautions	4
3.3 Installation Safety	5
4. Mechanical Installation	6
4.1 Installation Conditions	6
4.2 Tilt Angle Selection	7
4.3 Installation Methods	8
5. Electrical Installation	10
5.1 Installation Condition	10
5.2 Grounding	12
6. Maintenance	14

1. Introduction

1.1 Purpose

This document provides detailed instructions and valuable safety information regarding the installation, electrical connection, and maintenance of following Solahart Crystalline Photovoltaic modules:

- Solahart415C1
- Solahart420C1
- Solahart445C1
- Solahart450C1
- Solahart455C1

All the instructions should be read and understood before installation. The installers should be trained and conform to all safety precautions in this guide when installing module. Keep this guide in a safe place for further reference.

1.2 Limitation of Liability

Solahart assumes no responsibility for loss, damage or expense resulting from improper installation, handling or misuse of PV modules.

Solahart reserves the right to change the manual without prior notice.

2. Codes and Regulations

The mechanical and electrical installation of PV systems should be performed in accordance with all applicable codes, including electrical codes, building codes and electric utility interconnection requirements. Such requirements may vary for mounting locations, such as building rooftop applications. Requirements may also vary with system voltage, and for DC or AC application. Contact local authorities for governing regulations.

3. Safety

Solahart modules are designed to meet the requirements of IEC 61215 and IEC 61730, application class A. Modules rated for use in this application class may be used in system operating at greater than 50V DC or 240W, where general contact access is anticipated. Modules qualified for safety through IEC 61730-1 and IEC 61730-2 and within this application class are considered to meet the requirements for safety class II equipment.

3.1 General Safety

3.1.1 Consult and follow local codes and other applicable laws concerning required permits, as well as installation & inspection requirements, rules, and regulations.

3.1.2 PV modules should be installed and maintained by qualified personnel.

3.1.3 Use the same performance modules within a given series.

3.1.4 Follow all safety precautions of all components used in the system.

3.1.5 Do not shade portions of the PV module surface from the sun for a long period of time.

The shaded cell may become hot (hot spot phenomenon), which can result in solder joints peeling off.

3.1.6 Do not clean the glass surface with chemicals.

3.1.7 Do not drop the PV module or drop objects onto the PV module.

3.1.8 Do not concentrate sunlight on the modules or panels.

3.1.9 Do not attempt to disassemble the modules, and do not remove any attached components from the modules.

3.1.10 Do not scratch or hit at the back sheet, the glass, the terminal box. Do not pull the cables or touch the terminals with bare hands.

3.1.11 Do not drill holes in the frame or scratch the anodized film of the frame.

3.1.12 Keep the PV module packed in the carton until installation.

3.1.13 Do not use modules near equipment or in places where flammable gases may be generated.

3.1.14 Do not use modules in an environment with aliphatic, aromatic, phenols, ketones, halogenated substance or mineral oil, which may corrode the junction box by chemical attack.

3.2 Installation Precautions

3.2.1 Module's unpack and transfer

- a) When the whole pallet of modules is delivered to the site and unloaded, make sure the safety of the modules especially if they need to be lifted for roof projects. Put them into a protective device and then lift it to the roof to avoid bumping against the wall during the lifting process.
- b) Firstly, tear the stretch film, then move away the top cover after cutting off each module packing strip while unpacking.
- c) Two installers work as a group, if the modules are fixed with anti-inverted tapes, grasp the module frame tightly in the same direction and take out the module one by one. It is a must that the operators remove the adhesive tape of the fixed module one by one, rive one piece and then take out one piece of module. If the modules are fixed with packing belt, firstly cut the two packing belt, use non-sharp and dependable items such as anti-falling sticks to hold one side of the long side carton, and then cut the other side of the carton, two installers take out the modules one by one. Do not tear off all the adhesive tape at one time to prevent the whole package from toppling over or falling down. The whole process must be taken very gently. Don't collide with any hard objects or let any parts of the frame touch and drag on the ground.
- d) After unpacking, the modules should be installed that day as far as possible. It's recommended to take the right amount of modules according to the progress of the project every day. Heavy rain and other inclement weather may have the potential to soak the packaging which can affect product reliability, such as storms, typhoons, hurricanes or other events in which they may be blown away. Do not open the package if the modules need to be stored before installation. The modules should be stored at room temperature in a dark, dry and ventilated place.

3.2.2 Module Stacking

- a) When a module is taken out of the box, cardboard bedding below should be applied in order to avoid contact with cement surface / ground, hard metal or tile. Modules should be placed neatly and should not be dropped, slammed or scratched.
- b) When stacking modules, it needs to be stacked neatly in the horizontal plane, under the condition of the glass facing down and the back way piled up, while the cardboard bedding need to be underside the modules. If the modules will be installed on the rooftop, the number of each stack is suggested no more than 20. In case of the poor load-bearing capacity, it's recommended that the designer and/or installer check with the structural engineer or architect to determine the amount of load allowable for specific location. During the whole process, the installation tools and other objects must be prevented from contacting the module surface.
- c) If the modules are requested to be classified by current, the handling personnel are required to carry out of the level of the current and make a mark separately according to the power on the list. (e.g. 275W-L, identifies the modules of the packaging according to the power on the list, indicating a low

current position; 275W-H, compared to high current position). Usually, the same series of modules in the same current position are required in accordance with the system design requirements.

d) If the modules are color-coded and marked the corresponding logo on the carton due to the customer requirements, when modules are taken out and stacked, they should be labelled to avoid confusion. Usually the same row or the same square have the same colour according to the system design requirements.

e) Due to the complexity and differences of the construction sites, these precautions may not cover all items, please refer to the specific construction standards.

3.3 Installation Safety

3.3.1 Wear protective clothing such as head gear, insulating gloves, safety shoes as prescribed by local safety codes. Use insulated tools when installing the modules.

3.3.2 Do not install the modules in heavy rain, snow, or otherwise wet or windy conditions.

3.3.3 Completely cover the PV module surface with an opaque material during PV module installation and wiring to prevent accidental charge build-up.

3.3.4 Plug in connectors tightly when working on wiring.

3.3.5 Due to the risk of electrical shock, do not perform any work if the terminals of PV module are wet.

3.3.6 Do not touch the terminal box and the end of output cables (connectors) with bare hands.

3.3.7 Do not unplug the connector under load.

3.3.8 Do not work alone.

3.3.9 Wear a safety harness if working far above the ground.

3.3.10 Do not wear metallic jewellery, which can cause electric shock, while installing or troubleshooting the PV system.

3.3.11 Follow the safety regulations for any and all other system components, including wires, connectors, charging regulators, batteries, inverters, etc.

3.3.12 Do not expose wires to direct sunlight. Use UV-resistant cables.

3.3.13 Do not damage the surrounding PV modules or mounting structure when replacing a PV module.

3.3.14 Do not change any PV module components (diode, junction box, connectors, etc.).

3.3.15 The maximum reverse current is 20.25A for module with $I_{sc} \leq 9.61A$ and 27A for module with $I_{sc} > 9.61A$. Application of the blocking diode and fuse in the combiner box are recommended for reverse current protection when more than two strings are connected in parallel.

3.3.16 A certain gap is maintained between the PV module and the mounting surface to prevent the mounting surface touching the junction box.

3.3.17 Standing on the solar PV module is forbidden and also prohibit installation tools or other objects hitting surface of the solar PV module.

3.3.18 The solar modules are recommended to be installed over a fireproof and insulating roof covering when installed on a roof.

3.3.19 PV cable connection cannot be too tight, it is recommended that the connector and the back sheet have a certain gap.

3.3.20 In sandy regions, in order to avoid getting sand into the connector, we suggest to short circuit module connectors before installation. If grains of sand get into the connectors, it may cause internal live parts wear and tear and affect electrical safety.

4. Mechanical Installation

4.1 Installation Conditions

4.1.1 Extreme environment temperature range: $-30^{\circ}C$ to $+50^{\circ}C$

4.1.2 Operating temperature range: $-40^{\circ}C$ to $+85^{\circ}C$

4.1.3 Mechanical load on panels (e.g., snow/wind): The max tested snow/wind load is 5400Pa/2400Pa, and the design load is 3600Pa/1600Pa under standard mounting system. For specific installation methods and mechanical load test values, please refer to 4.3 detailed component installation instructions.

4.1.4 The modules mounting structure must be made of durable, corrosion-resistant and UV-resistant material. Modules must be securely attached to the mounting structure.

4.1.5 In regions with heavy snowfall in winter, select the height of the mounting system, so that the lowest edge of the modules is not covered by snow for any length of time. In addition, ensure that the lowest portion of the modules is placed high enough so that it is not shaded by trees or other plants.

4.1.6 When the modules are supported parallel to the surface of a building roof, a minimum clearance of 10 cm between the module frame and the surface of the roof is required to allow air to circulate behind the modules and to prevent wiring damage.

4.1.7 Solahart modules are designed to meet the requirements of IEC61730 and UL 61730, application the fire performance Class C (IEC61730) and type 4 (UL61730).

4.1.8 Due to the linear thermal expansion of the modules frames, the installer must ensure that the minimum distance between neighboring module frames is 10 mm.

4.2 Tilt Angle Selection

The tilt angle of the modules is measured between the surface of modules and the horizontal plane, as shown in figure a. The modules generate maximum power output when they face the sun directly.

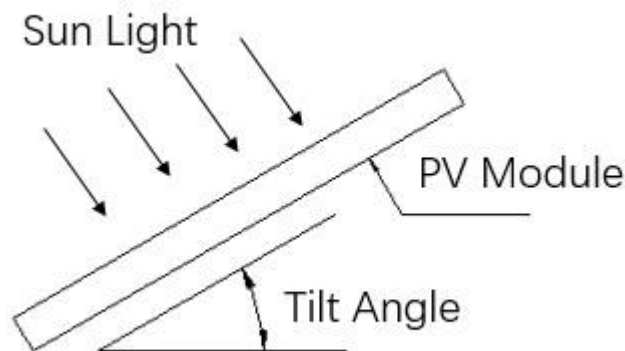

Figure a: Schematic diagram of tilt angle

In northern hemisphere, modules should typically face south, and in southern hemisphere, modules should typically face north. Dust building up on the surface of the modules can impair module performance, Solahart recommends installing the modules with a tilt angle of at least 10 degrees, making it easier for dust to be washed off by rain. At the same time, it is conducive to the flow of accumulated water on the surface of the module and avoids long-term large amounts of accumulated water leaving marks on the glass surface, thereby affecting the appearance and performance of the module.

PV modules connected in series should be installed in the same orientation and angle. If the orientation and angle are different, the solar radiation received by each module may be different, resulting in power loss.

4.3 Installation Methods

4.3.1 Clamping on the frame surface

Modules can be laid across the rails as illustrated in Figure b.

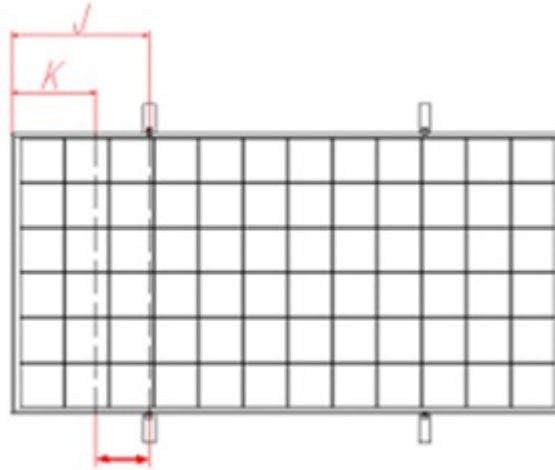

Figure b: clamping method

Remark:

- 1) The length of rails must be longer than the length of module frame.
- 2) Figure b illustrates the permissible clamping zone for mounting modules on the frame with aluminium clamps. Please refer to 4.3.3 for the specific recommended installation position and corresponding load.
- 3) Each clamp is equipped with an M8 bolt, a flat washer, a spring washer and an M8 nut. The fixing steps are as follows:
 - a) Place the module on two rails. The rails should be made with stainless material and treated with an anti-corrosion process (e.g., hot dipped galvanizing). Each PV module needs at least four clamps to fix. Do not make the clamp contact the glass directly or deform the aluminium frame in the installation process. Avoid shadowing the PV modules after installation, otherwise may damage the modules.
 - b) Be sure to avoid shadowing effects from the module clamps. Weep holes on the module frame must not be closed or obscured by the clamps. The clamp must overlap the module frame by at least 8 mm, but no more than 11 mm (The clamp section can be changed under the premise of ensuring the reliable installation of the components).
 - c) The rail's top surface contacted with module frame should come with grooves compatible with an M8 bolt.

- d) If the rails do not come with grooves, holes of a suitable diameter may need to be drilled to allow bolts to be attached to the bars at the same locations as mentioned above.
- e) Secure each clamp by attaching plain washer, spring washer, and nut, in that order.
- f) The torque for tightening the nut and bolts are recommended to be 17~23 Nm.

4.3.2 Component installation range and Mechanical load value

The specific Mechanical load value and installation scope of Solahart PV modules are shown in the following table.

Module type	Dimension	Installation range J - K	Mechanical load
Solahart415C1 Solahart420C1	2018 x 1002 x 35 mm	300 - 450 mm	+5400Pa/-2400 Pa
Solahart445C1 Solahart450C1 Solahart455C1	2094 x 1038 x 35 mm	350 - 450 mm	+5400Pa/-2400 Pa

5. Electrical Installation

5.1 Installation Condition

5.1.1 Rated electrical characteristics such as I_{sc} is within $\pm 5\%$ and V_{oc} within $\pm 3\%$ and P_{mpp} within $\pm 3\%$ of tolerance values at Standard Test Conditions. Standard Test Conditions:

1000W/m² Irradiance, 25°C Cell Temperature and 1.5 Air Mass.

5.1.2 The IEC & UL standard maximum system voltage is 1500V. The maximum voltage of the system must be less than the maximum certified voltage and the maximum input voltage of the inverter and of the other electrical devices installed in the system.

The open circuit voltage of the array string needs to be calculated at the lowest expected ambient temperature for the location. This can be done using the following formula:

$$\text{Max System Voltage} \geq N \times V_{oc} \times [1 + TC_{VOC} \times (T_{min} - 25)]$$

N	No modules in series
V_{oc}	Open circuit voltage of each module (refer to product label or data sheet)
TC_{VOC}	Thermal coefficient of open circuit voltage for the module (refer to data sheet)
T_{min}	The lowest ambient temperature

5.1.3 Connect quantity of modules that match the voltage specifications of the inverters used in system. Modules must not be connected together to create a voltage higher than the permitted maximum system voltage under the lowest local temperature conditions.

5.1.4 Under normal conditions, a photovoltaic module is likely to experience conditions that produce more current and/or voltage than reported at standard test conditions. Accordingly, the value of I_{sc} marked on this module should be multiplied by a factor of minimum 1.25, when determining component conductor ampacities, fuse sizes, and size of controls connected to the PV output. Refer to AS/NZS for additional requirements.

5.1.5 Refer to AS/NZS 5033, when determining the voltage rating, conductor capacity, fuse rating, and photovoltaic output control size.

5.1.6 Each module (or series-connected string of modules) shall be provided with the maximum series fuse, specified at 20A.

5.1.7 Modules with different electrical characteristics must not be connected directly in series.

5.1.8 Use a special solar cable and plugs for installing the PV system and make sure that all connections are safe and tight. The cable should be minimum 4 mm² (12AWG), and able to withstand the maximum possible system open-circuit voltage.

5.1.9 Cables should be fixed to the mounting structure in such a way that mechanical damage of the cable and/or the modules is avoided. Don't apply stress to the cables. For fixing, use appropriate means, such as sunlight resistant cable ties and/or wire management clips specifically designed to attach to the module frame. While the cables are sunlight resistant and waterproof, where possible, avoid direct sunlight exposure and water immersion of the cables.

5.1.10 The junction boxes in these PV modules contain bypass diodes wired in parallel with the PV cell string. The bypass diode in the junction box can prevent the degradation of component performance caused by shading or covering (such as aging of packaging materials, sealing-off, etc.). Refer to the junction box diode specifications provided in the relevant product specifications.

5.1.11 In the case of partial shading, the diodes bypass the current generated by the non-shaded cells, thereby limiting modules heating and performance losses. In the event of a known or suspected diode failure, installers or maintenance providers should contact Solahart. Never attempt to open the junction box.

5.1.12 Do not connect different types of connectors.

5.1.13 Keep connectors dry and clean, and ensure that connector caps are hand tight before connecting the modules. Don't attempt making an electrical connection with wet, soiled, or otherwise faulty connectors. Avoid sunlight exposure and water immersion of the connectors. Avoid connectors resting on the ground or roof surface.

5.1.14 Don't disconnect under load. When it is necessary to open the connector, make sure that the component is in a non-working state, and must use a professional unlocking tool, and avoid pulling the connectors hard.

5.2 Grounding

5.2.1 Solahart modules use an anodic oxidized aluminum frame to resist corrosion. So the frame of modules should be grounded to prevent thunder and electrical shock. The grounding device should fully contact with the inside of the aluminum alloy, and penetrate the surface of the frame oxidation film.

5.2.2 Solahart recommends using the following methods to ground modules for rooftop PV installations only:

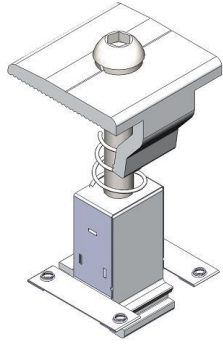
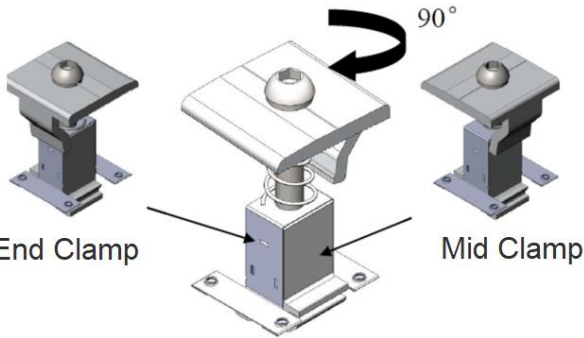
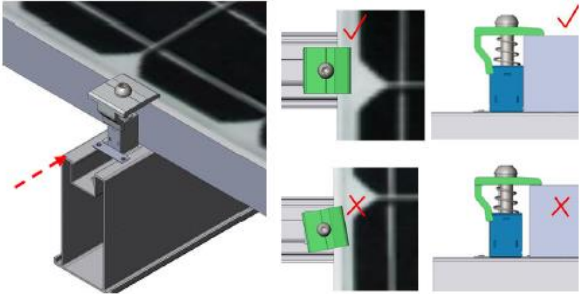
 <p>Universal clamp with Earthing plate for frame height 30 to 46 mm (C-U/30/46-G)</p>	<p>To earth modules and rails, use Clenergy Universal Clamps with earthing plates (C-U/30/46-G) when mounting modules. Install the clamps in accordance with the following instructions. When installed correctly, earthing plates will provide earth bond continuity between rails and modules whilst allowing removal of a module without affecting the earthing integrity of other components in the system.</p>
 <p>End Clamp Mid Clamp</p>	<p>Universal Clamps with built-in earthing plates suit PV modules of thickness between 30 mm to 46 mm and can be used as either mid clamps or end clamps. Twisting the head of the clamp changes the functionality from end clamp to mid clamp.</p>
	<p>When using as end clamp, slide the universal clamp to the position to be fastened. Ensure there is at least 25 mm from the rail end. Then slightly slide the PV Module frame onto the earthing plate of universal clamp. Make sure the frame of PV Module is fully in contact with the universal clamp. Ensure that the end clamps are tight against the module. Then tighten the universal clamp bolt to minimum 17 Nm.</p>

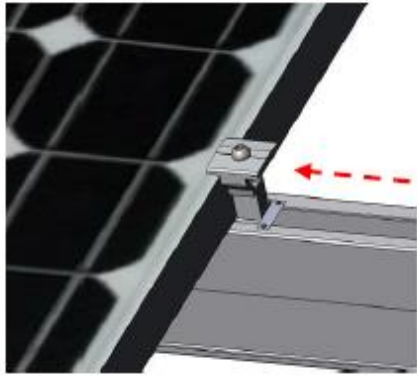

Inserting the clamps. Ensure the frame of PV module is fully in contact with the universal clamp.

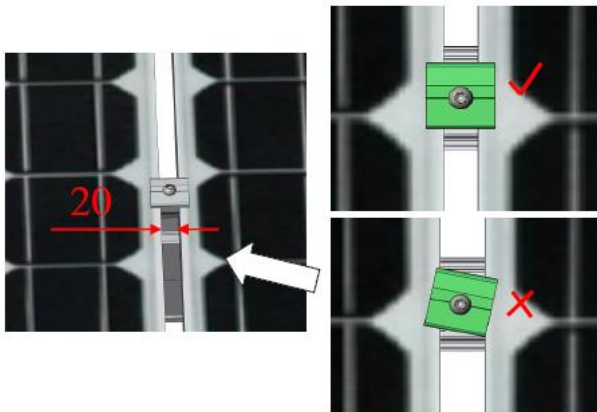

Slightly slide the next PV Module into the other side of universal clamp, ensure the frame of PV Module is closely in contact with the universal clamp. Visually check to ensure the universal clamp and PV module are properly positioned. Then tighten the universal clamp bolt to 18-20 Nm.

Ensure both module frame edges are located on top of the protrusions of the earthing plate.

Repeat the last two steps for each remaining module in the row.

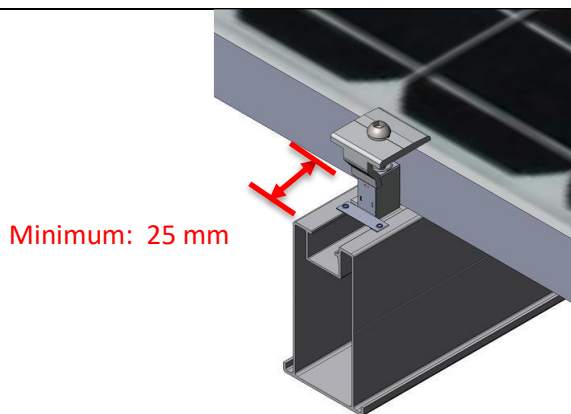

Place a universal clamp into the end of each rail. Ensure that the end clamps are tight against the module and are at least 25 mm from the rail ends.

Ensure the frame of module is located on top of the protrusions of the earthing plate. Tighten the universal clamp bolts to minimum of 17 Nm.

6. Maintenance

It is required to perform regular inspection and maintenance of the modules, especially within warranty scope. It is the user's responsibility to report to the supplier regarding the damages found in time.

6.1 Regularly carry out a visual inspection for dirt, dust, bird dropping, leaves, and other detritus covering the modules.

6.2 If snow is present, a soft-bristled brush with soft bristles may be used to clean the surface of the modules.

6.3 Regular electrical and mechanical inspection by a licensed professional will keep the system safe and operating at maximum efficiency.

6.4 Recommended PV module Clean-up period

To get high output performance, PV module needs to be cleaned-up periodically as below:

① Normal: Minimum once a month; Dust weather: Right away after the dust wind;

② The period of the PV module cleaning shall be determined by the condition of the weather & pollution.

6.5 If there is a lot of dirt on the surface of the modules, use clean water and a soft cleaning tool (such as a sponge) to clean the modules array during a cooler time of the day. Do not scratch the dust on the surface of the modules in a dry condition, otherwise it will cause scratches.

6.6 Condition of Cleaning

6.6.1 Use clean water or filtered water with soft type material (a sponge) to wipe the PV modules. Never use chemicals on the surface of the module.

6.6.2 Cleaning after sunset or before sunrise is recommended.

6.6.3 Do not use abrasive powder, abrasive cleaners, scrubber cleaners, polishers, sodium hydroxide, benzene, nitro-thinners, acid or alkali and other chemical substances.

6.6.4 Do not clean broken glass or modules with broken or exposed wires, as it may cause electric shocks.

Revision B Issue Date 18/06/2021