

OWNER'S MANUAL

with

Warranty and Installation Information

for

Solahart Gas Boosted Solar Water Heaters

Thermosyphon Models 150, 180, 220, 300, 440

using

**Gas Heating Element FD15 – 12
(Part Number 10141500)**



FOR SERVICE PLEASE CALL 1800 638 011
OR YOUR LOCAL SOLAHART DEALER

Solahart Industries Pty Ltd ABN 45 064 945 848

Corporate Headquarters:	112 Pilbara Street, Welshpool, Western Australia 6106
Postal Address	P.O. Box 95, Welshpool, Western Australia 6986.
Telephone	International + 61 8 9351 4600
Facsimile	International + 61 8 9351 4698
Email	solahart@solahart.com.au
Internet	http://www.solahart.com.au

CONTENTS

SECTION NO.	SECTION	PAGE
1	General Information	3
2	Model and Type of Appliance	3
3	Data Plate Details	3
4	Installation Details	4
5	Appliance Detail	4
6	Installation Types	5
7	Methods of Installation	6
8	Installation Procedure	8
9	Service Instructions to Gas Fitter	10
10	Conversion from Natural Gas to Propane	11
11	Conversion from Natural Gas to TLP	11
12	Assembly Diagram	12
13	Technical Data	13
14	Operating Instructions	15
15	Maintenance	15
16	Warranty Policy	16

1. GENERAL INFORMATION

Important : This System is Unsuitable for use as a pool heater.

The system must be installed in accordance with these installation instructions by an authorised and licensed person in accordance with the following criteria:

- The installation instructions herein.
- Local gas fitting regulations.
- AS 5601 Gas Installations.
- AS/NZS 3500.4 Plumbing and Drainage - Heated Water Services.
- AS/NZS 3000 Electrical Installations (Wiring Rules).

2. MODEL AND TYPE OF APPLIANCE

The model number is stated on the Silver Data Label located around the Gas Heating Element flue terminal.

These instructions refer to domestic Gas Boosted Thermosyphon Solar Water Heaters for outdoor installation only.

This Gas Heating Element is designed for fully automatic operation and is controlled by an electric thermostat mounted onto the storage tank adjacent the burner tube location.

Gas Heating Element FD15 - 12

Used with Solahart **Thermosyphon** Solar Water Heater models 150, 180, 220, 300 and 440

3. DATA PLATE DETAILS

The following Gas Heating Element information is contained for easy reference on the silver data plate located around the flue terminal of the unit.

- a) TANK SERIAL NUMBER
- b) GAS TYPE
- c) GAS PRESSURE SETTINGS
- d) VALVE SETTINGS
- e) OPERATION WARNINGS
- f) LIGHTING INSTRUCTIONS
- g) NAME PLATE
- h) AGA BADGE

Refer to Section 12 for a diagram of the data plate location.

4. INSTALLATION DETAILS

- 4.1 Gas:** Check that the available gas is suitable for use with the heater. The gas type is printed on the data plate.
- 4.2 Packaging:** We have taken great care in protecting the Gas Element and storage tank during transport. If, however, the water heater is damaged contact the supplier immediately. Ensure that all packaging is removed from the Gas Element flue way before installation.
- 4.3 Installation Procedure:** Refer to section 8.
- 4.4 Before Leaving:** Do not leave before having tested the operation of the water heater and instructed the user regarding operation details.
- 4.5 Testing:** Gas inlet pressures vary throughout Australia. The rated capacity is related to the burner pressure. Ensure that the gas inlet and burner pressures comply to the data plate specification.
- 4.6 Regulator:** The gas control regulator is set to comply with the data plate. If burner pressure is too high, the regulator may be adjusted. Refer section 9.6 (b) for details. If burner pressure is too low firstly adjust the regulator as above, however if the pressure cannot be raised it is possible that the inlet pressure is low. In that case, contact your gas supplier for correction prior to final commissioning of the system.
- 4.7 Incorrect Performance:** If the burner pressure is more than 10% lower than the pressure shown on the data plate and this corresponds with a 10% lower inlet pressure, the system will not operate correctly, you must contact the gas supplier.

If the gas system cannot be adjusted to perform in accordance with these instructions contact your local Solahart supplier.

Other than gas pressure and thermostat settings there are no owner or installer adjustable components within the system. If the system does not operate automatically, switch OFF the gas and electrical supplies and contact your local Solahart supplier for immediate rectification.

5. APPLIANCE DETAIL

Refer to section 13 for the dimension and connection details of each model Solar Water Heater.

6. INSTALLATION TYPES

Models 150, 180, 220, 300 and 440 are Thermosyphon Solar Water Heaters and use Gas Heating Element FD15 - 12. This manual covers in detail the gas installation only. Refer to the "Solahart" Owners manual for complete solar and water circuit installation and commissioning instructions.

Prohibited Locations: The following diagram (Figure 1) summarises schematically prohibited locations for flue terminals contained in the AS 5601 Gas Installations Standard. If any doubt exists consult your local gas supply authority prior to completing the installation.

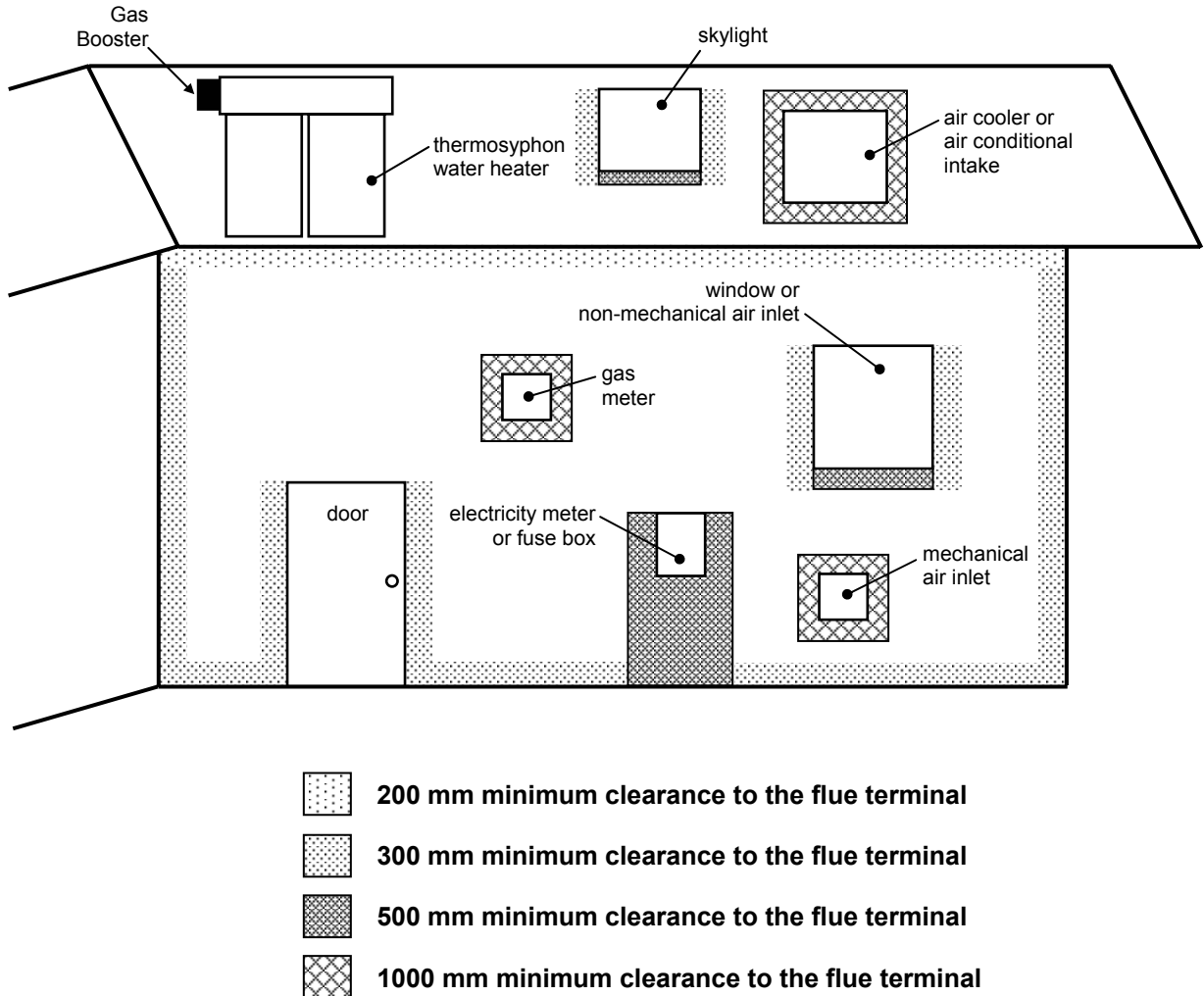

Figure 1 Prohibited Locations

NOTE: Always read this diagram in conjunction with AS 5601 Gas Installations Standard

7. METHODS OF INSTALLATION

7.1 Location

Refer to local requirements concerning clearance for water heater etc. Figure 1 (refer to page 5) shows general clearances for a typical outdoor installation. Where local authority requirements contradict Figure 1, the former should apply.

NOTE: To avoid possible contamination from flue gases, ensure that existing household air intakes such as coolers, fresh air intakes from air-conditioning plants etc. are at least 1.5 metres from the gas flue terminal

7.2 Special Conditions

The Solahart Gas Heating Element can only be installed into a Solahart thermosyphon water heater system. Each Gas Heating Element requires a permanent gas supply (of the type shown on the data plate) and a permanent 240 Volt AC or 12 Volt DC power supply. Without either supply being available, the system cannot operate.

7.3 Gas Connection

- (i) The gas connection supplied is a 3/8" female BSP fitting. It requires an appropriate flared adaptor for connection to 3/8" or 15 mm copper tube.
- (ii) Location - Left rear of the Gas Heating Element. Refer section 13 for details.
- (iii) Pipe sizing guides can be found in AS 5601 Gas Installations Standard. Typical gas consumption of this system is 13 MJ per hour.
- (iv) An isolating gas valve must be fitted at a convenient height adjacent the system to allow quick and easy isolation of the gas supply to the Gas Element.

7.4 External Installation Only

Gas Heating Elements are designed for external installation only. There are no circumstances where an internal installation is approved.

7.5 Cold Water Connection

- (i) Refer to the Typical Thermosyphon System Plumbing Diagram (Figure 2 on page 7) for cold supply pipe work connection locations. Thermosyphon System supply is connected to the tank fitting marked "Inlet".
- (ii) Maximum supply pressure with an Expansion Control Valve (ECV) is 850 kPa.
- (iii) Recommended Expansion Control Valve (ECV) pressure setting is 850 kPa
- (iv) Maximum supply pressure without Expansion Control Valve (ECV) 850 kPa.

NOTE 1: Where these pressures are exceeded a pressure reduction valve must be fitted.

NOTE 2: The connection method is with a combination of stop cock, non-return valve, pressure limiting valve and expansion control valve located at ground level. Refer to AS/NZS 3500.4 clause 5.9.3.

7.6 Hot Water Connection

- (i) Refer to the Typical Thermosyphon System Plumbing Diagram (Figure 2 on page 7) for hot supply pipework connection locations.

- (ii) The Temperature Pressure Relief Valve is rated at 99°C and 1000 kPa.
The Thermosyphon System Temperature Pressure Relief Valve is inserted into a tee piece which is in-turn inserted into the tank fitting marked "Outlet".
- (iii) Hot Water connection
The Thermosyphon System pipework is connected to the outlet port of the tee piece fitted to the tank fitting marked "Outlet" with the use of a disconnection union (refer AS/NZS 3500.4).
- (iv) A copper drain line must be fitted to the relief valve to carry the discharge clear of the water heater. Connect the drain line to the relief valve using a disconnection union. The pipe work from the relief valve to the drain should run to ground, be as short as possible and fall all the way from the water heater with no restrictions. It should have no more than three right angle bends in it. Use DN15 pipe.

The outlet of the drain line must be in such a position that flow out of the pipe can be easily seen (refer to AS/NZS 3500.4) - but arranged so hot water discharge will not cause injury, damage or nuisance. The drain line must discharge at an outlet or air break not more than 9 metres from the relief valve.

In locations where water pipes are prone to freezing, the drain line must be insulated and not exceed 300 mm in length. In this instance, the drain line is to discharge into a tundish through an air gap of between 75 mm and 150 mm.

Warning: As the function of the temperature pressure relief valve on this water heater is to discharge high temperature water under certain conditions, it is strongly recommended the pipe work downstream of the relief valve be capable of carrying water exceeding 93°C. Failure to observe this precaution may result in damage to pipe work and property.

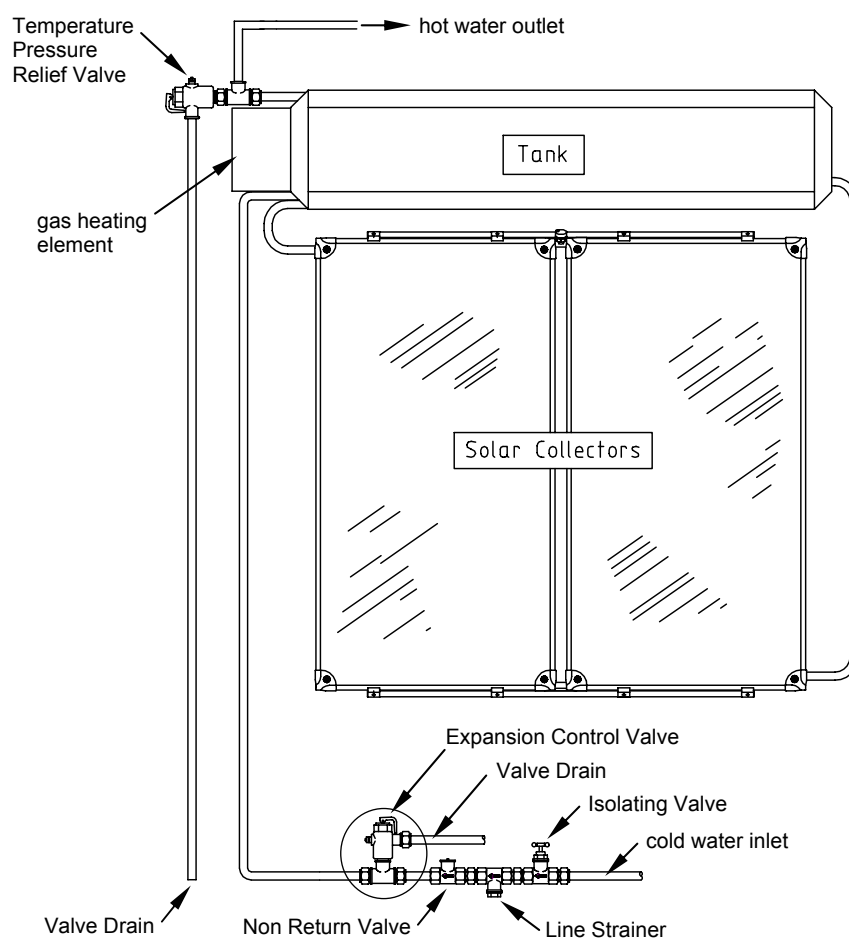

Figure 2 Typical Thermosyphon System Plumbing Diagram

8. INSTALLATION PROCEDURE (Gas Element in Retro Fit Applications Only)

Thermosyphon Systems are supplied disassembled and will require site assembly as detailed below. The existing heating element must be removed before installing the Gas Element. For the

The following work must be carried out by a qualified gas fitter or plumber with gas fitting licence.

Check that the correct gas supply is available for the appliance and that 240V AC or 12V DC supply is available at an adjacent power outlet or connection point in a weather proof location.

- 8.1** Remove the Gas Element unit from its packaging and fit the heat exchanger assembly with O Ring (fit onto the flange cap) into the opening in the storage tank and secure in place using the six bolts through the mounting flange. Ensure that the "T" mark on flange is at the top. Use the handle of a hammer (for example) as a lever to assist in tube placement. Tighten the six bolts in rotation until the flange cap is in position and parallel with the back flange, then tighten each bolt diagonally until a torque of approximately 12 to 13 Nm is reached (10 ft lbs). The stainless steel flue baffle plate within the heat exchanger tube is marked at the top, check this to ensure correct positioning of both the burner tube and baffle plate.
- 8.2** Connect the cold water to the storage tank and turn on the water supply venting air from the tank via either operate the temperature / pressure relief valve or opening a hot water outlet. Once all air is expelled allow the tank to fill and pressurize before checking the flange cap and O Ring for leakage.
- 8.3** Fix the base plate onto the black end of the tank with screws and reinforcement plate supplied. Assemble the thermostat onto the mounting plate adjacent the tank entry flange. Plug the thermostat cables into the matching plug on the control loom.
- 8.4** Check burner alignment and spark electrode position and slide the burner assembly into the burner tube, at the right hand side of the stainless steel baffle plate.
- NOTE:** Do not apply pressure to the elbow fitting, this may misplace the burner alignment and spark electrode position. Softly tap on the Burner Location Plate Cut if the burner assembly is tight to fit to the burner tube.
- 8.5** Connect the gas tube from the solenoid to the burner assembly.

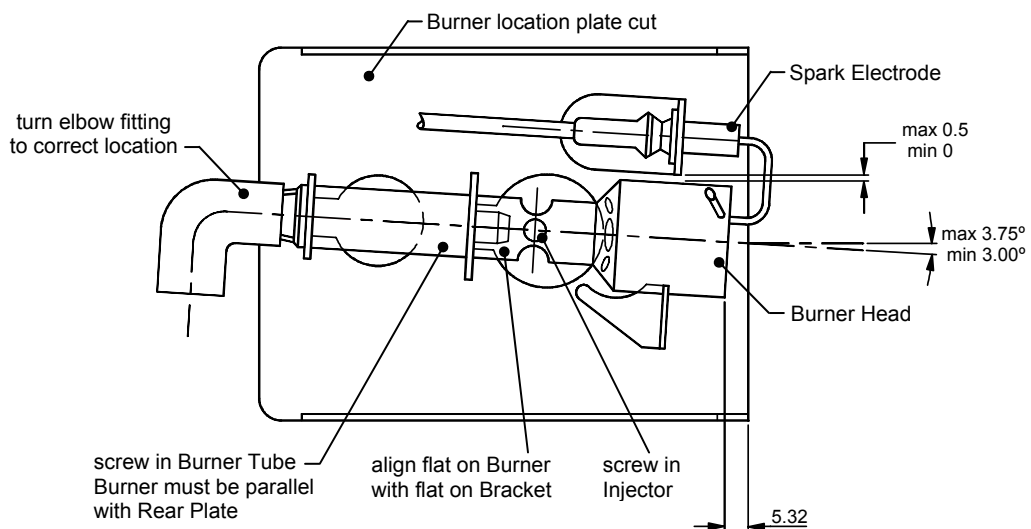

Figure 3 Burner Assembly

- 8.6** Pass the spark electrode with the rubber grommet through the burner cone and fit the grommet into the hole. Now fit the cone over the burner tube so that the cone divider tongue slips in on the right hand side adjacent to the baffle plate then abuts the burner assembly plate. Continue to push the cone down over the burner tube while aligning the slot at the base of the cone with the 6 mm diameter gas tube.
- 8.7** Plug in fan wires (red to the spade connector in the electronic control module and the black to the loose socket in the wiring loom adjacent the electronic control module). Slide the spark electrode connector lug onto the spade terminal on the electronic control module. Connect the two fan air pressure pipes to the fan control switch. (Refer to diagram in Section 12 on page 12 for location details)
- 8.8** Fit transformer pack into closest available power point (ensure power is off) and run 12V DC supply cabling to the Gas Element using the electrical entry and a flexible conduit complete with termination fittings. The transformer pack comes complete with 1.8 meters of 2 core flex which can be extended using a terminal block and the required length of 1 mm² x 2 core figure 8 flex. Connect the supply cable to the terminal block mounted on the mounting frame adjacent the electrical control module.
- NOTE:** The transformer pack is not weather proof and must be located in a protected area free of moisture.
- 8.9** Electrical wiring must comply with the requirements of AS/NZS 3000 regarding sizing, protection, workmanship, waterproofing, clipping etc.
- 8.10** Check gas supply is correct for the appliance and connect with nominal 3/8" BSP or 15 mm copper pipe to the gas supply. Fit a gas isolation cock and bleed gas pipe at Gas Element to remove air.
- NOTE:** The fitting from 3/8" BSP female to copper and the gas isolating cock are not supplied. A 3/8" male BSP and 15 mm copper flare union or copper cone/olive union will be required to affect a 15 mm copper gas pipe connection.
- 8.11** Turn ON the gas supply and power supplies. The Gas Heating Element should now sequence through a start cycle. Entrapped air in the gas pipework may create the necessity for several start cycle attempts before continuous operation is established.
- NOTE:** Without the cover fitted, flue gas can re-enter the fan suction giving poor combustion and consequently will shut the unit down. Should it be necessary during commissioning to temporarily operate the unit without the flue terminal fitted a temporary divider plate can be used in the cone to separate the two air streams.
- 8.12** Check all pipe joints for gas leakage. Check test point gas pressure to ensure it measures 1.0 kPa (NG) 2.6 kPa (PROPANE) or 0.62 kPa (TLP).
- 8.13** Check that the gasket inside the flue terminal is in position and undamaged. Fit the flue terminal cover to Gas Heating Element and secure it to the base plate using the 6 screws provided. Apply pressure to the end of the flue terminal while tightening screws to ensure flue terminal gasket is correctly seated. Check burner combustion via sight glass in the flue terminal cover.
- 8.14** Switch power to the transformer ON and OFF several times (allowing 60 seconds between each switch) to prove that the Gas Heating Element cycles correctly.
- 8.15** Instruct house owner in system operation. Ensure a copy of the Solahart Owner's Manual is handed to the owner. Clean away unwanted materials.

9. SERVICE INSTRUCTIONS TO GAS FITTER

Any service which requires the removal of any components should be carried out by Authorised Personnel only.

Turn OFF the gas and electrical supplies to the unit before removing any components.

Burner operation can be viewed with the cover in place through the sight glass in the flue cover. Fan operation is also visible through this window.

Air control to the burner is factory set. No primary air re-adjustment is required when changing from NG to PROPANE or TLP.

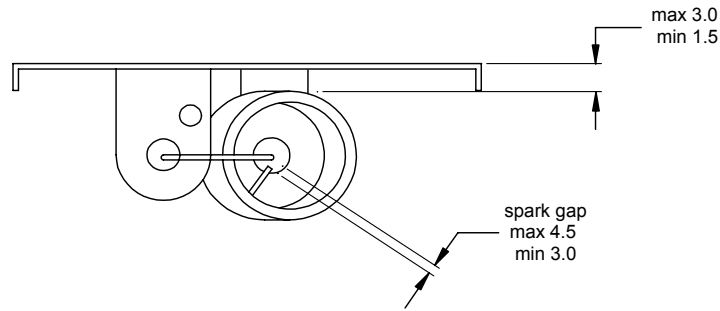

Figure 4 Spark Electrode Settings

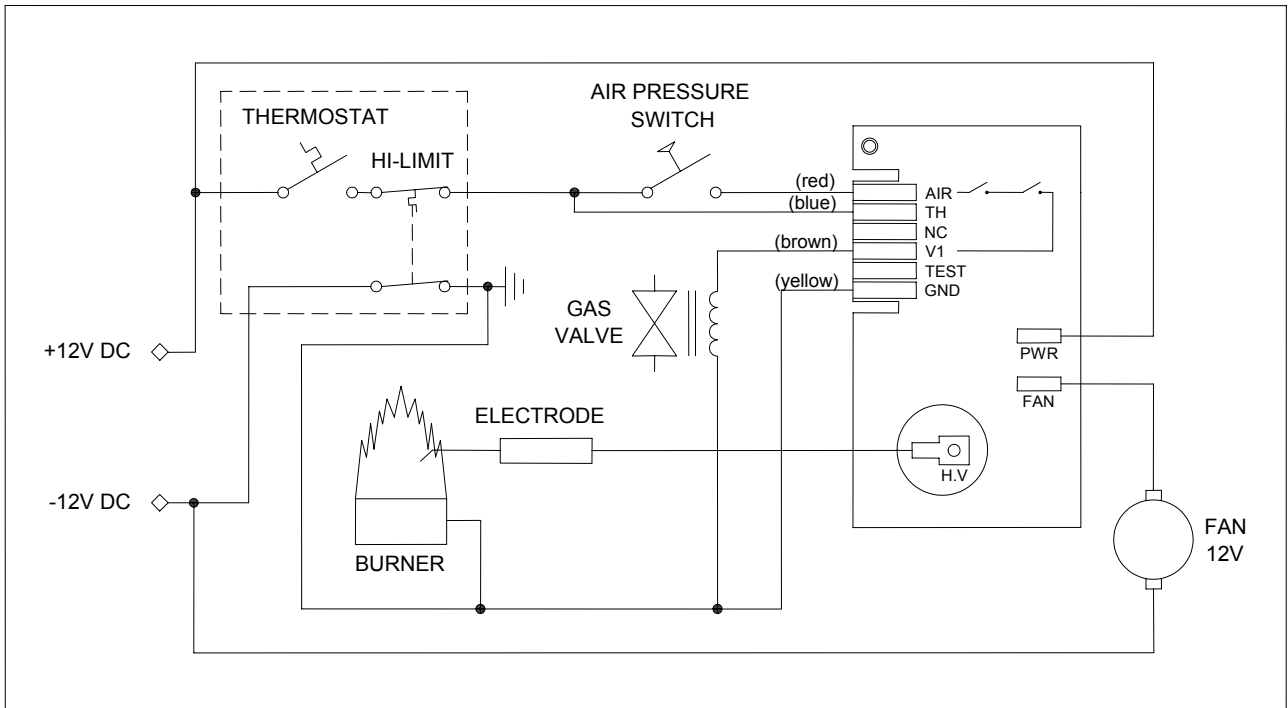

Figure 5 Controller Wiring Diagram

- 9.1 Flue Terminal Cover Removal.** To remove the cover panel, unscrew the six screws around the cover and withdraw the cover. Re-assemble in the reverse order. If required, the Gas Element can be operated without the cover but ensure the flue gas and fan intake are separated with a temporary baffle to prevent flue gas recirculation.
- 9.2 Position of Spark Electrode:** Check that the spark electrode is correctly positioned so that the electrode is approximately 3 mm into the flame, an air gap of 3 to 4 mm is available for the spark gap and that the electrode does not approach within 10 mm of the burner edge.
- 9.3 Fan and Burner Removal:** After removing flue terminal cover, unplug the fan wiring; disconnect the air control pipes, remove the fan plate (slide off the three spring clips); remove the cone (ease off); feed the electrode wire back through the grommet in the cone as the cone is being withdrawn; disconnect the gas supply to the burner at its connection; remove the burner assembly. To refit the burner and fan, follow reverse procedure.
- 9.4 Complete Gas Element Assembly Removal:** Remove the cover panel; drain the hot water tank to a level at least below the bottom of the heat exchanger tube, remove the burner cone assembly; disconnect the gas supply to the burner; remove the thermostat and base plate containing the double solenoid valve/gas regulator and electronic controller; unbolt the 6 bolts which hold the heat exchanger tube into the storage tank and remove the heat exchanger tube. To refit, follow the reverse procedure ensuring a new heat exchanger O Ring seal is placed on the exchanger flange before inserting. Ensure the mating surfaces are clean.
- 9.5 Thermostat Access:** Access is achieved by removal of the flue terminal cover as detailed in 9.1 Remove the thermostat from the clamp and lift it off the tank mounting.
- 9.6 Adjustments:** Burner aeration, gas pressure regulation and ignition systems are set and tested during manufacture and should not need adjustment. If however, conditions have occurred which result in adjustments being required, the following should be conducted by an authorised person.
- (a) **Burner Aeration:** This is factory set and cannot be adjusted.
 - (b) **Gas Pressure Regulator Adjustment:** If adjustment should be necessary, proceed as follows. Rotate the central adjustment screw "clockwise" to increase or "counter clockwise" to decrease pressure; use either of the two side outlets of the regulator for connecting a pressure test device.
NOTE: Regulator pressure adjustment should be carried out with the burner operating.
 - (c) **Ignition System (spark gap):** Remove burner assembly as described above; the spark gap may be adjusted by bending the electrode into the desired position - the electrode is factory set to ignite at the top right hand edge of the flame via the ignition pin (the best spark position for the flame establishment has been found to be the position shown in Figure 4, (it is strongly recommended that this location be used); replace burner assembly and re-test the spark.

10. CONVERSION FROM NATURAL GAS TO PROPANE

Use only the Propane Conversion Kit (FD15 - 12) (part number 12104105) supplied and authorised by Solahart. The kit will contain all components and instructions required for safe conversion of Gas type.

11. CONVERSION FROM NATURAL GAS TO TLP

Use only the TLP Conversion Kit (FD15 - 12) (part number 12104103) supplied and authorised by Solahart. The kit will contain all components and instructions required for safe conversion of Gas type. "TLP" means tempered liquefied petroleum.

12. ASSEMBLY DIAGRAM (FD15 - 12 Gas Heating Element)

1	470071	Base Plate	12	470376	Gas Pipe
2	346010	Thermostat	13	470368	Solenoid / Regulator
3	470500	Electronic Controller	14	470480	Fan
4	470006	Heat Exchanger Tube	15	470826	Data Plate
5	470354	NG Burner Injector or	16	470008	Flue Terminal Assembly
	470357	Propane Burner Injector or	17	416262	Fixing Screw
	470361	TLP Burner Injector	18	470657	Elbow
6	470009	Burner Head	19	470010	Baffle Plate Assembly
7	470353	Burner Tube	20	470506	Differential Air Pressure Switch
8	470016	Spark Electrode	21	470680	High Air Pressure Connection
9	470484	Transformer	22	470045	Low Air Pressure Connection
10	330169	O Ring	23	470058	Wiring Loom Assembly
11	470007	Burner Cone Assembly			

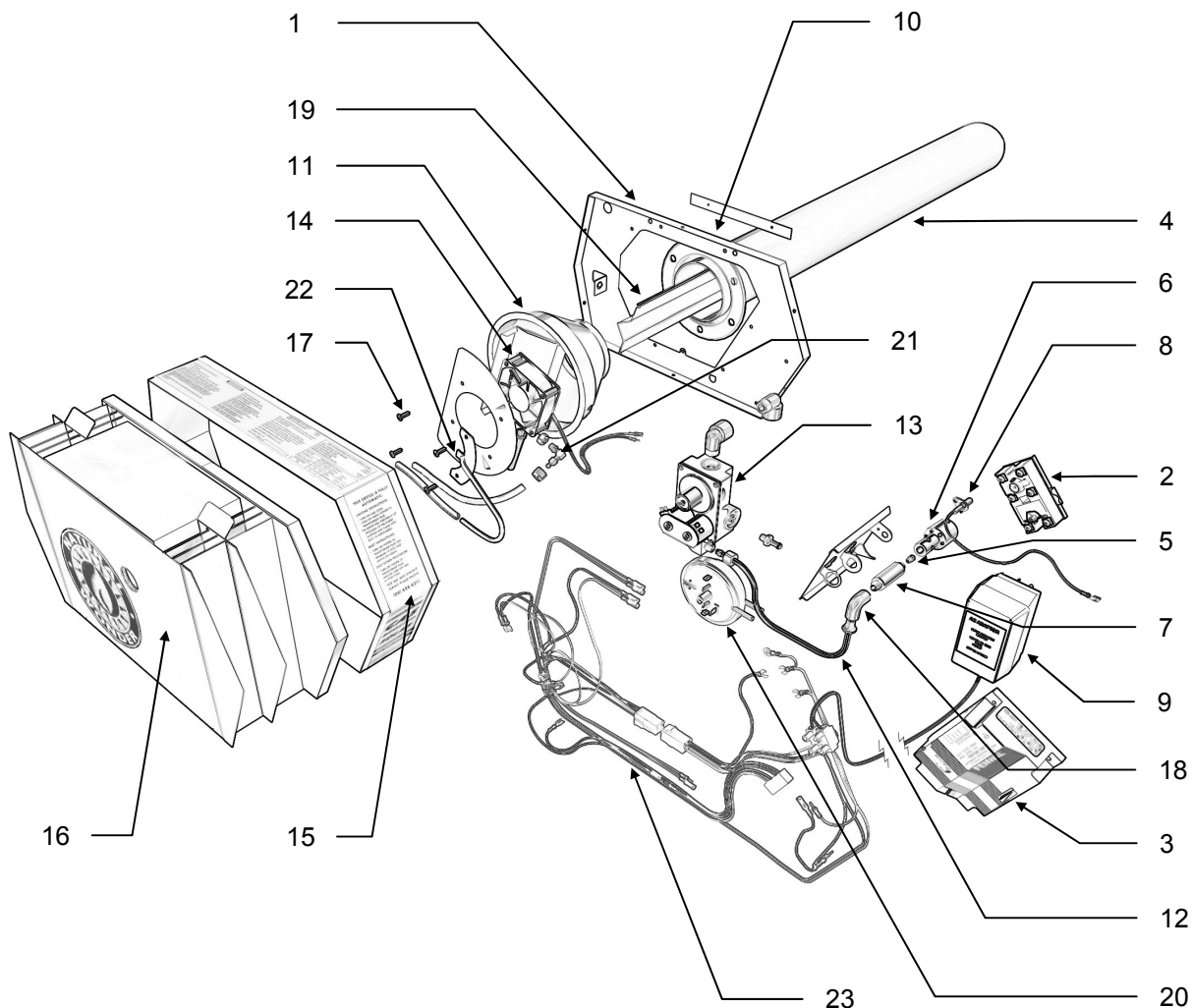
**Figure 6 Assembly Diagram**

13. TECHNICAL DATA

STORAGE TANK

Model	System Type	Boost Capacity (L)	Storage Capacity (L)	TPR Valve Pressure (kPa)	Max Supply Pressure (with ECV) (kPa)	ECV Valve Pressure (kPa)
150	Thermosyphon	90	150	1000	850	850
180	Thermosyphon	110	180	1000	850	850
220	Thermosyphon	130	220	1000	850	850
300	Thermosyphon	180	300	1000	850	850
440	Thermosyphon	260	440	1000	850	850

GAS

Gas Type	NG	PROPANE	TLP
Jet Diameter mm	1.75	1.05	2.9
Gas Consumption MJ/hr	13	13	13
Burner Test Point Pressure kPa	1	2.6	0.62

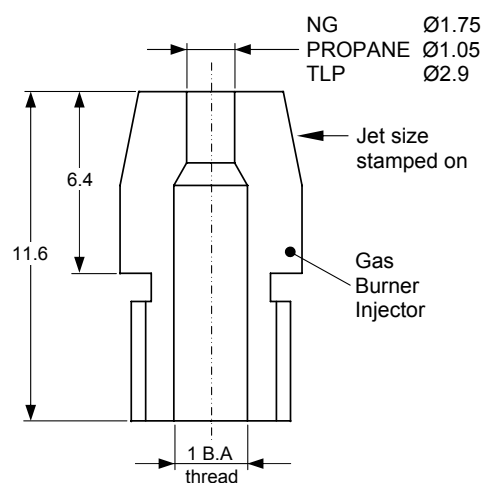

Figure 7 Burner Injector

Gas connection: 3/8" BSP Female

NOTE: A special conversion kit is available for PROPANE and TLP gas (refer to page 11).

ELECTRIC

Power supply:	12V DC	1.5 A
Fan:	12V DC	3.6 W (maximum)
Solenoid/regulator:	White Roger's 25M26V 701 12V DC 0.48A Max. pressure 3.5 kPa	
Electronic controller:	Fenwal Series 35-53 12V DC	
Thermostat:	Robertshaw SA203 EWT1L2S-203 Trade Adjustable, factory set at 60°C	

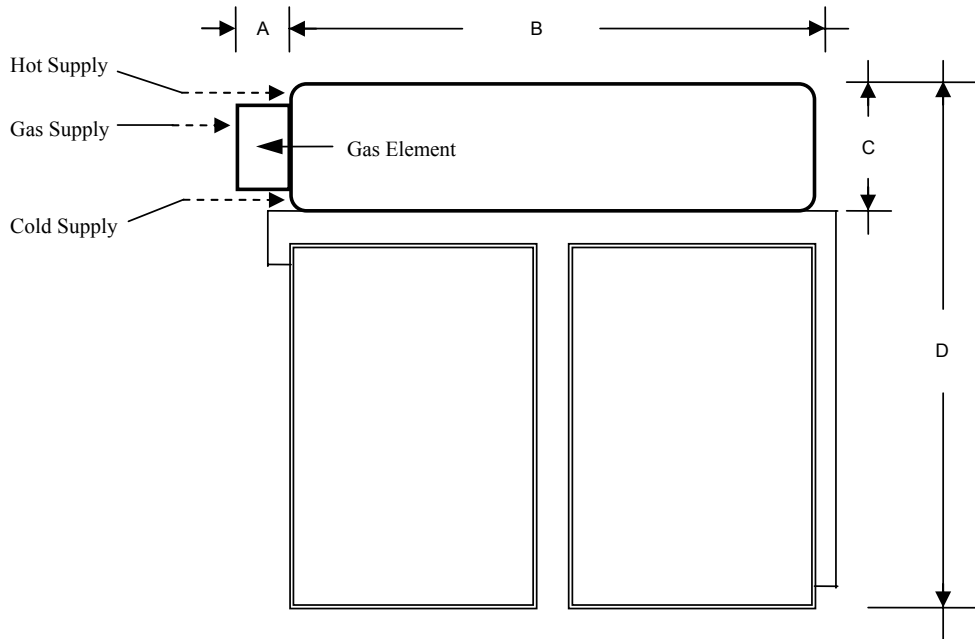
DIMENSIONS (mm)

Model	150	180	220	300	440
A	180	180	180	180	180
B	1280	1494	1760	2310	3285
C	510	510	510	510	510
D	2475	2475	2475	2475	2475

Figure 8 Thermosyphon System Outline Dimensions

14. OPERATING INSTRUCTIONS

For the safe and efficient operation of your gas water heating system there are some simple precautions which must be observed.

APPROVED FOR OUTDOOR INSTALLATION ONLY

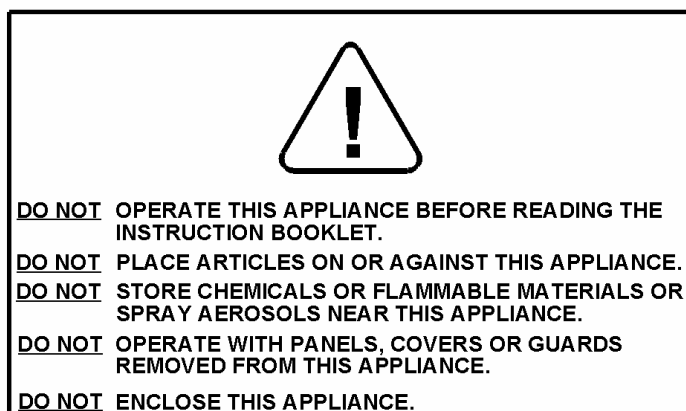

The system must be filled with water before lighting. Operating instructions for lighting procedure will also be found on the data name plate on the cover of the Gas Element. The Gas Element is fully automatic and is factory adjusted for correct combustion. A gas shut off valve is provided by the installer to isolate the gas supply to the Gas Element and must be in the ON position.

Electric power is supplied to the Gas Element via a 12V DC transformer pack plugged into a power point fitted adjacent the heater. The Gas Element can be isolated electrically by turning off the power to the transformer pack. For the Gas Element to operate, both gas and electric power supplies must be available.

LIGHTING THE GAS SYSTEM

Ensure that the gas and power is turned ON to the unit. When the water temperature is below the factory thermostat setting the Gas Element will automatically enter a start sequence. Firstly the fan will start to clear the unit of any un-burned gasses for approximately 15 seconds during which time the control system will check that the fan has started and is operating correctly. Secondly the electronic sparker igniter will light the burner, and check that the flame has been established. If the flame has not been established the gas valve will close and the start up procedure will be repeated once more. If the unit fails to light for the second time, the Gas Element will switch into a lock out mode. Turning the power to the unit off for 20 seconds will reset the unit for operation. If this lock out continues to occur when the gas supply is available the unit should be checked by your local dealer.

After the start up sequence the Gas Element will cycle automatically on the thermostat and maintain a storage water temperature of approximately 60°C in the storage tank. This temperature can be adjusted by an authorised service person.

Visual indication of burner operation is available through a sight glass on the Gas Element cover, or by observing the gas meter, the meter needle will move slightly faster when the Gas Element is on. If the Gas Element appears not to be heating it may be reset by turning the power off for 20 seconds then turn the power back on. If the gas isolating valve has been closed or the gas pipe has been disconnected, several reset attempts may be required before sufficient gas is available at the burner.

15. MAINTENANCE

- (i) Every six months the operating arm of the pressure and temperature relief valve should be raised to ensure that the valve is free and capable of discharging water pressure.
- (ii) The storage tank anode should be inspected every five years and changed if required to maximise the system life. The anode is located under the Gas Element housing for Thermosyphon Systems. Removal is achieved by unscrewing the anode fitting and withdrawing the anode. Re-installation is the reverse procedure.
- (iii) All valves should be checked and replaced if necessary every five years.
- (iv) The Gas Element should be checked every five years coinciding with the service on your hot water system. It should be checked for dust built up on the fan, soot build up in the heat exchanger, and the condition of the ignition sparker. Any components which are not as described in this manual should be replaced.

16. WARRANTY POLICY

(Worldwide)

Installation Details: The "Installation Details" sheet in the Owner's Manual must be completed and returned to Solahart.

The protection offered by the warranty policy below is in addition to all other non-excludable rights and remedies which the consumer has under the Trade Practices Act (in Australia) and similar state or territorial laws that may apply.

This warranty applies to systems installed in a single family domestic dwelling. A separate warranty policy applies for system installed in commercial, industrial or multi-family domestic dwellings.

This warranty applies to the Gas Heating Element only. Solar Hot Water System, collectors and control systems are covered by a separate warranty policy with different conditions. Please refer to your Solahart Owner's Manual for details.

Solahart (the manufacturer) warrants the system against defects, faulty materials and/or workmanship and leakage from corrosion upon the following terms.

FIVE (5) YEAR

Comprehensive warranty covering parts and labour, when installed with a new water heater

ONE (1) YEAR

Comprehensive warranty covering parts and labour, when installed as a retrofit to a water heater

CONDITIONS

The above is subject to an area within a 30 km radius of the Solahart dealer from whom the unit was purchased. Customers outside this area will be subject to freight and travelling charges incurred by the Solahart dealer carrying out the work.

A call out fee applies to warranty calls made outside normal Solahart business hours.

EXCLUSIONS

1. Where Gas Element corrosion has occurred when the anode has not been changed in accordance with the Owner's Manual.
2. The manufacturer shall be under no obligation under this warranty in the case of accident, Acts of God, installation/repairs carried out by others outside of Solahart installation and maintenance instructions or a Solahart accredited service agent or technician of a gas utility.
3. Subject to any statutory claims to the contrary, claims for damage to furniture, carpets, walls foundations or any other consequential loss either directly or indirectly due to failure of the Gas Element.
4. Where other plumbing or electrical components supplied by the installer such as pressure limiting valves, stop cocks, non-return valves, electrical switches, pumps or fuses fail.

RECOMMENDATIONS

Statutory Authorities and Codes recommend that the temperature pressure relief valve fitted to the storage tank be replaced at intervals not exceeding five years. Solahart also recommends that the anode be replaced at intervals indicated in the Owner's Manual.

FD15 – 12 PROPANE CONVERSION

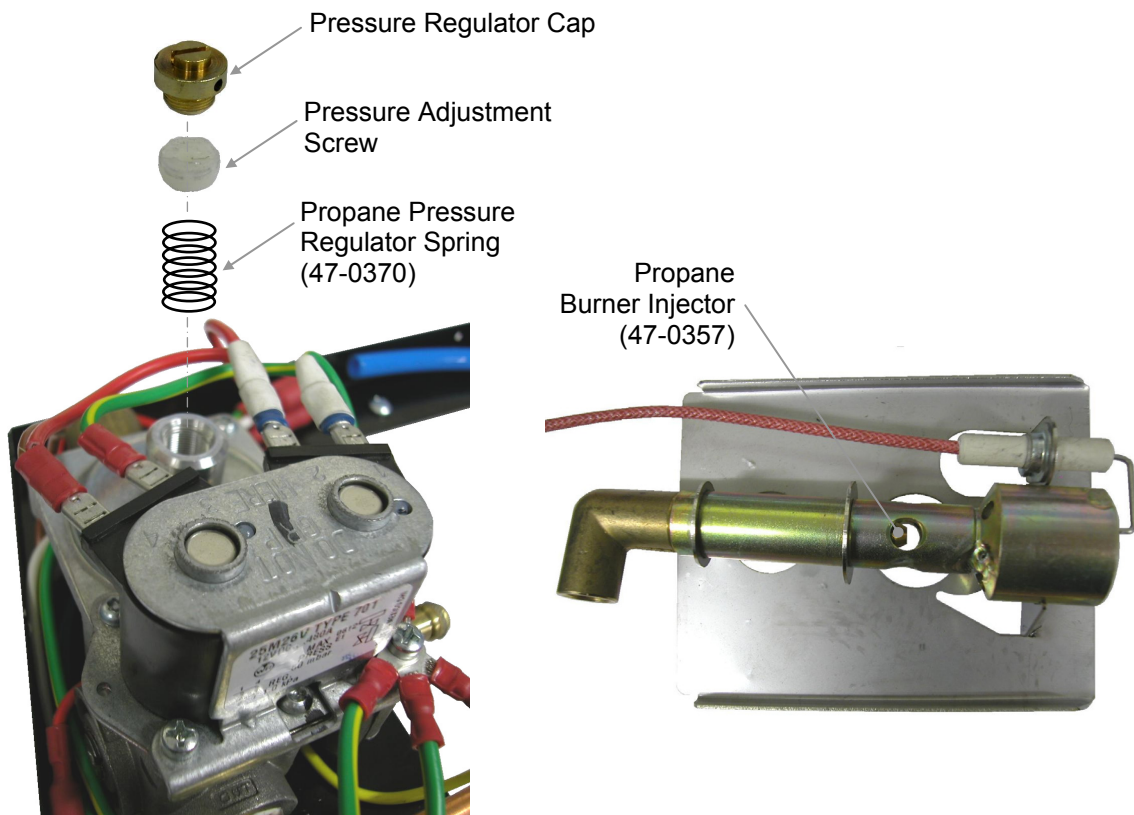

Conversion from Natural Gas to Propane

1. Remove the main cover, gas pipe connection, burner cone and burner (refer to Owner's Manual (47-0840) section 9.1, 9.2 and 9.3 on page 11).
2. Replace the 1.75 mm diameter burner injector with a 1.05 mm diameter Propane burner injector (47-0357).
3. Replace all components in the reverse order to the above.
4. Unscrew the pressure regulator cap and pressure adjustment screw, replace spring with the Propane pressure regulator spring (47-0370) which supplied in the Propane Conversion Kit (12104103).
5. Refit the pressure adjustment screw half way down. Fit a manometer to the test point. Operate the gas booster and adjust the pressure adjustment screw to get the test point pressure of between 2.55 to 2.6 kPa.
6. Refit the pressure regulator cap.
7. Affix the Propane Label (47-0818) to the main cover shield.
8. Refit the cover and operate the Gas Element. Check the burner flame and the reliability of the start cycle.

FD15 – 12 T.L.P. CONVERSION

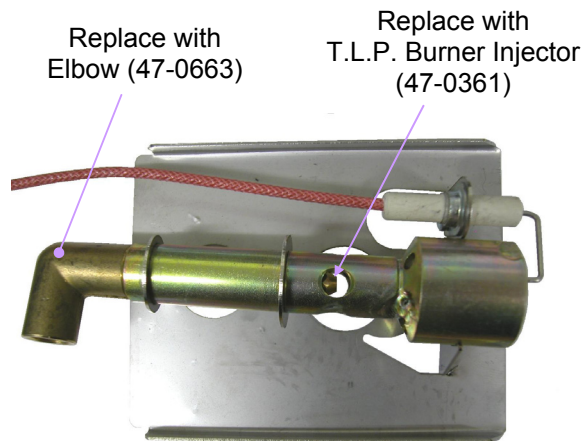
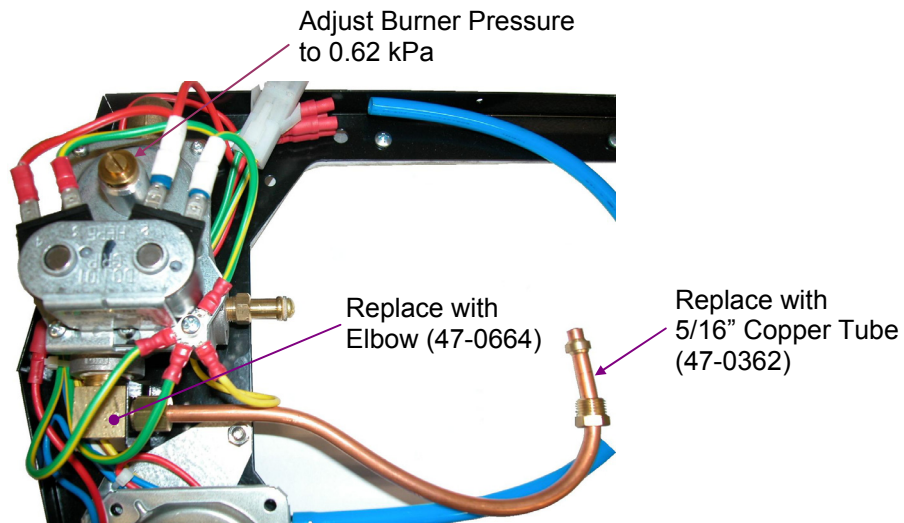

Conversion from Natural Gas to T.L.P.

1. Remove the male compression elbow (3/8" BSP – 1/4" tube) and replace with elbow (3/8" BSP – 5/16" tube) (47-0664). Use pipe sealant Loctite 567 or similar.
2. Replace the 1/4" copper tube with the 5/16" copper tube (47-0362).
3. Replace the Natural Gas burner injector with a 2.9 mm diameter T.L.P. burner injector (47-0361).
4. Remove the female elbow (1/8" BSP – 1/4" tube) from the burner tube and replace with elbow (1/8" BSP – 5/16" tube) (47-0663). Use pipe sealant Loctite 567 or similar.
5. Replace the gas type label on the main cover with the T.L.P. Label (47-0823).
6. Refer to the Owner's Manual (47-0840) for fitting of the gas booster to Solahart tank.
7. Adjust the burner pressure to 0.62 kPa before start up.
8. Check system for leakage and correct operation.