



J Series

Description

The Solahart J Series is a roof mounted, closed circuit system specifically designed to provide efficient service in medium to high solar gain areas.

The high efficiency black polyester powder coated absorber maximises the transfer of available solar energy while the closed circuit design makes it suitable for frost prone and poor water quality areas.

The J Series utilises Solahart's revolutionary multi-flow collector which uses a huge 35 risers to extract the maximum amount of energy from the sun.

The double ceramic lined tank has a protective sacrificial anode, and the J Free Heat features additional anode protection. The tank is equipped with an electric booster, alternatively an in line gas booster is available.

Most J and J Free Heat systems can be installed with the HartStat OTP (over temperature protection) system to prevent over performance during periods of higher solar radiation and lower hot water draw off.

Key Features

- Optimum performance in medium and high solar gain areas
- Suitable for frost prone or harsh water areas
- Stylish slimline design
- Thermosiphon operation minimises maintenance
- Gas booster or electric booster models available
- Double coated ceramic lined tank
- Enhanced protection on Free Heat model
- Free Heat series available in 180 and 300 litre capacities

Key Benefits

- Can save up to 50% to 85% of water heating energy consumption*
- Reliable, low maintenance operation
- Hot water regardless of the weather
- Can qualify for valuable environmental incentives*
- Reduced energy use can save up to 2.1 to 3.2 tonnes of CO₂ emissions per annum*
- Peace of mind with 10/5/5[†] (J Free Heat), 5/5/5[†] (J Series) year warranties

* Energy savings of up to 50% to 85% shown are based on Australian Government approved TRNSYS simulation modelling using a medium load. Savings and incentives will vary depending upon your location, type of Solahart system installed, orientation and inclination of the solar collectors, type of water heater being replaced, hot water consumption and fuel tariff. Maximum financial savings off your hot water bill are achievable when replacing an electric water heater on continuous tariff. Refer to solahart.com.au for further information.

[†] Solahart Warranty Details: 10/5/5 warranty, 10 year cylinder and collectors supply, 5 year parts, 5 year labour; 5/5/5 warranty, 5 year cylinder and collectors supply, 5 year parts, 5 year labour.

Thermosiphon J and J Free Heat Closed Circuit Systems

These systems are suitable for multiple installations. They are suitable for frost and harsh water regions.

J and J Free Heat Systems																
Model		150 tank	151 system	180 tank	181 system	182 system	220 tank	221 system	222 system	300 tank	301 system	302 system	303 system	440 tank	443 system	444 system
Tank model																
J		150J	✓	180J	✓	✓	220J	✓	✓	300J	✓	✓	✓	440J	✓	✓
J Free Heat		-	-	180F	✓	✓	-	-	-	300F	✓	✓	✓	-	-	-
Collector model			J		J	J		J	J		J	J	J		J	J
No of collectors			1		1	2		1	2		1	2	3		3	4
HartStat OTP	optional	-	✓	-	✓	✓	-	NA	✓	-	NA	✓	✓	-	✓	✓
Storage capacity	litres	150	150	180	180	180	220	220	220	300	300	300	300	400	400	400
	US gal	40	40	48	48	48	58	58	58	80	80	80	80	106	106	106
Boost capacity (electric)	litres	75	75	90	90	90	110	110	110	150	150	150	150	200	200	200
	US gal	20	20	24	24	24	29	29	29	40	40	40	40	53	53	53
Weight empty	kg	56	102	66	108	154	78	124	170	99	145	187	229	148	290	320
	lbs	123	225	146	238	340	172	273	375	218	320	412	505	326	639	705
Weight full	kg	206	256	245	292	338	298	348	394	399	449	495	541	588	730	776
	lbs	454	564	540	644	745	657	767	869	880	990	1091	1193	1296	1609	1711
A – Width*	m	1.40	1.40	1.62	1.62	2.42	1.88	2.04	2.42	2.43	2.43	2.43	3.38	3.41	3.49	4.44
	in	55.1	55.1	63.8	63.8	95.3	74.0	80.3	95.3	95.7	95.7	95.7	133.1	134.3	137.4	174.8
B – Length*	m	0.51	2.63	0.51	2.63	2.63	0.51	1.64	2.63	0.51	1.64	2.63	2.63	0.51	2.63	2.63
	in	20.1	103.5	20.1	103.5	103.5	20.1	64.6	103.5	20.1	64.6	103.5	103.5	20.1	103.5	103.5

* An additional 0.9m (35.4in) should be left on all four sides of the installation for safe access and servicing.

NA - Not available.

The J and J Free Heat systems (if installed with a HartStat OTP system) can be installed as a solar preheater with an inline Solahart gas booster water heater. Refer to the Solahart gas booster specification sheet for further details on the gas booster.

J Collector					
Aperture (heating) area	m ²	1.87	ft ²	20	
Dimensions	length	mm	1937	in	76.3
	width	mm	1022	in	40.3
	height	mm	77	in	3.0
Capacity	litres	3.5	US gal	0.9	
Weight	empty	kg	42	lbs	93
	full	kg	46	lbs	101
Working pressure	kPa	80	psi	12	
Absorber surface	Black polyester powder coat				
Absorber material	steel				
Riser material	steel				
Number of risers	35				
Tray material	0.7mm aluminium				
Insulation material (base)	38mm polyester blanket				
Glass	3.2mm tempered low iron				

Electric Boost Specifications				
Heating unit type *	Copper sheath immersion element			
Supply voltage	220 V – 250 V			
Recovery rate @ 240 V and temperature rise of:				
Rating kW	Current Amps	30°C litres/hour	40°C litres/hour	50°C litres/hour
1.8	8	51	39	31
2.4	10	68	52	41
3.6	15	103	77	62
4.8	20	137	103	83

* A bobbin element (2.5 kW) is available for hard or corrosive water areas

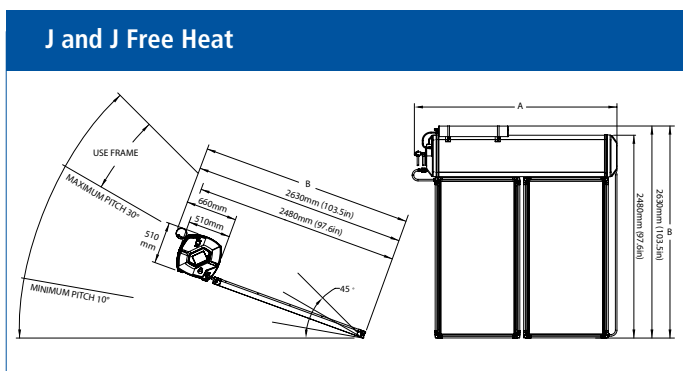

Water Supply				
TPR valve setting	kPa	1000	psi	145
ECV* setting	kPa	850	psi	125
Max. supply pressure with ECV	kPa	680	psi	100
	kPa	800	psi	115
Water Connections	cold	RP ¾ / 20		
	hot	R ½ / 15		

*Expansion Control Valve

Energy Tip: When installing your solar water heater, install minimum 3 star rated shower roses and flow restrictors to your taps if you don't already have them. This will not only save water but make your solar savings go further.

Technical data is subject to change

Solahart Australia Tel: 1300 769 475 www.solahart.com.au
Solahart International Tel: +61 8 9351 4600 www.solahart.com

SH930J 2012 January