

Installation Instructions

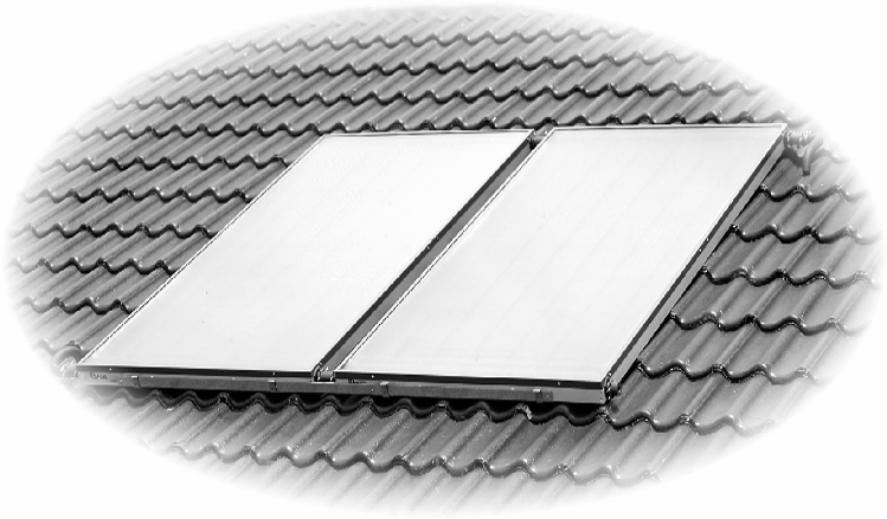

Solar Collector Kit

Solar Collector Add On Kit



WARNING: Plumber – Be Aware
Use copper pipe **ONLY**. Plastic pipe **MUST NOT** be used.
It is a requirement of a solar water heater installation that all pipe work be in copper and not plastic, due to the effects of high water temperatures and pressures.

*This collector kit must be installed and serviced by an authorised person
Please leave this guide with the householder.*

**Notice to Victorian Customers from the
Victorian Plumbing Industry Commission.**

**This water heater must be installed by a licensed person as required by
the Victorian Building Act 1993.**

Only a licensed person will give you a Compliance Certificate, showing that the work complies with all the relevant standards. Only a licensed person will have insurance protecting their workmanship for 6 years. Make sure you use a licensed person to install this water heater and ask for your Compliance Certificate.



WARNING: Plumber – Be Aware

- The solar hot and solar cold pipes between the solar storage tank and the solar collectors **MUST BE** of copper and fully insulated with closed cell polymer insulation or similar (minimum thickness 13 mm). The insulation must be weatherproof and UV resistant if exposed. All compression fittings must use brass or copper olives.

Note: Failure to observe this requirement may void the warranty for freeze damage.

- Plastic pipe **MUST NOT** be used, as it will not withstand the temperature and pressure of the water generated by the solar collectors under stagnation conditions. The solar collectors can generate extremely high water temperatures, up to 150°C, and high water pressure of 1000 kPa. Plastic pipe cannot withstand these temperatures and pressures, and **MUST NOT** be used. Failure of plastic pipe can lead to the release of high temperature water and cause severe water damage and flooding. Refer to Warning on page 11.

PATENTS

This water heater may be protected by one or more registered designs.

CONTENTS

HOUSEHOLDER - This installation instruction booklet is intended for the installer but you may find it of interest.

Installation – Solar Storage Tank	4
Solar Collector Location	5
Roof Assembly Of Solar Collectors	7
Connection Details	12
Pipe Work Roughing In Dimensions.....	18
Installation – Solar Collectors	20
Warranty Note	24

SOLAR COLLECTOR KIT AND COLLECTOR ADD ON KIT

For installation with a solar storage tank.

Your solar water heater is designed for the solar collectors to be roof mounted and the solar storage tank to be installed at ground or floor level. The collector kits are suitable for:

Collector Kit (2 solar collectors)

299123	SBT 200 ('FB') solar collectors	Quick Connect fittings
299139	NPT 200 ('N', 'L') solar collectors	Screwed fittings

Collector Add On Kit (1 additional solar collector)

299125	SBT 200 ('FB') solar collector	Quick Connect fittings
299140	NPT 200 ('N', 'L') solar collector	Screwed fittings

Note: One Collector Add On Kit is required for each additional solar collector.

INSTALLATION – SOLAR STORAGE TANK

THIS WATER HEATER IS NOT SUITABLE FOR POOL HEATING.

The system is suitable for installation with either SBT 200 ('FB') or NPT 200 ('N', 'L') solar collectors. The system is not suitable for installation above 800 metres altitude.

The system when installed in areas subject to freeze conditions must be installed with SBT 200 ('FB') solar collectors and the solar hot and solar cold pipes must be fully insulated with closed cell polymer insulation (minimum thickness 13 mm) to offer protection against freeze damage. Freeze conditions occur below 6°C. The system has NO WARRANTY for freeze damage when installed above 800 metres altitude or installed with NPT 200 ('N', 'L') solar collectors or if the solar hot and solar cold pipes are uninsulated (refer to "Warranty Note" on page 24).

SOLAR WATER HEATER STORAGE TANK LOCATION

The solar storage tank is suitable for either outdoor or indoor installation. Whether located outdoor or indoor, the solar storage tank should be installed close to the most frequently used outlet and its position chosen with safety and service in mind.

Consideration must also be given to the position of the solar storage tank in relation to the solar collectors. There are limitations on the maximum length of the solar hot and solar cold pipes between the solar storage tank and the solar collectors. Refer to "Solar Collector Location" on page 5 and to "Pipe Lengths" on page 6.

Refer to the installation instructions supplied with the solar storage tank for installation details of the solar storage tank.

SOLAR COLLECTOR LOCATION

Consideration must be given to the position of the solar collectors in relation to the solar storage tank. There are limitations on the maximum length of the solar hot and solar cold pipes between the solar storage tank and the solar collectors. Refer to “Solar Storage Tank Location” on page 4 and to “Pipe Lengths” on page 6.

- The solar collectors must be installed in a shade free position.
- The solar collectors are to be installed facing toward the equator (i.e. north facing in the southern hemisphere and south facing in the northern hemisphere). Where this orientation is not practical, a system facing up to 45° from the equator will have its efficiency reduced by approximately 5%.
- Inclination of the solar collectors should be approximately equal to 90% of the local latitude angle. The latitude of some Australian cities are listed on page 6. Solar collectors may be installed at the roof angle for simplicity of installation and appearance, but must never be flat. If the roof angle varies by 15° from the correct angle, efficiency will be reduced by 5%.
- For a solar collector installation on a roof with a pitch less than 10°, a variable pitch stand is required. Refer to your local Solar Distributor for details.
- For an installation at right angles to (across) the roof pitch, a flat roof stand and an across pitch stand are both required. Refer to your local Solar Distributor for details.
- For an installation opposite to (against) the roof pitch, a flat roof stand and an against pitch stand are both required. Refer to your local Solar Distributor for details.
- The collector kit is suitable for installations with an inclination of up to 30°. Where the solar collectors are installed at inclinations greater than 30°, a with pitch frame is necessary. Refer to your local Solar Distributor for details.

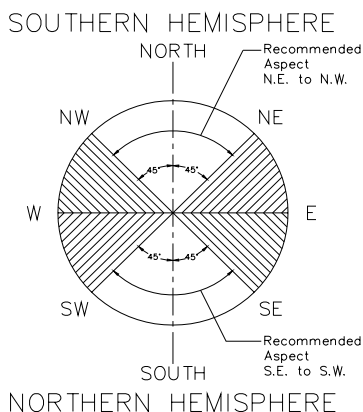

SOLAR COLLECTOR LOCATION

- The installation must comply with the requirements of AS/NZS 3500.4 and all local codes and regulatory authority requirements.
- The roof must be suitable to take the mass of the solar collectors. Each solar collector and its fittings weighs approximately 40 kg when full of water.

PIPE LENGTHS

The maximum recommended combined length of the solar cold and solar hot pipes with bends is:

Maximum recommended pipe length and number of 90° bends						
Pipe Size	1 or 2 Collectors		3 Collectors		4 Collectors	
	Pipe Length	90° Bends	Pipe Length	90° Bends	Pipe Length	90° Bends
DN15	40 metres	20	30 metres	20	15 metres	20
DN20	NR	NR	40 metres	20	40 metres	20

For each additional 90° bend, reduce the maximum total pipe length by 0.5 metres.

For each additional metre of pipe length, reduce the number of 90° bends by two.

Note: One 90° elbow is equal to two 90° bends.

NR – not recommended.

LATITUDE OF SOME AUSTRALIAN CITIES

Adelaide	35°S	Cairns	17°S	Hobart	42°S	Port Hedland	20°S
Alice Springs	24°S	Canberra	35°S	Mildura	34°S	Rockhampton	24°S
Brisbane	27°S	Darwin	12°S	Melbourne	38°S	Sydney	34°S
Broken Hill	31°S	Geraldton	28°S	Perth	32°S	Townsville	19°S

ROOF ASSEMBLY OF SOLAR COLLECTORS

Roof area required:

- 4 Solar collectors – 4.6 m wide x 2.0 m deep. Weight (full) 160 kg approx.
- 3 Solar collectors – 3.5 m wide x 2.0 m deep. Weight (full) 120 kg approx.
- 2 Solar collectors – 2.4 m wide x 2.0 m deep. Weight (full) 80 kg approx.
- 1 Solar collector – 1.3 m wide x 2.0 m deep. Weight (full) 40 kg approx.

Notes:

- All plumbing work must be carried out by a qualified person and in accordance with the National Plumbing Standard AS/NZS 3500.4 and local authority requirements.
- Ensure the roof structure is suitable to carry the full weight of the solar collectors. If in doubt the roof structure should be suitably strengthened. Consult a structural engineer.
- Do not remove the solar collector packaging completely, prior to the installation. Remove only sufficient packaging material to enable the installation. Upon completion of the installation it is necessary to leave the solar collector packaging covering the glass and fittings on the solar collector. The packaging should not be removed until the solar collector is filled with water and ready for use, otherwise damage to the solar collector can occur.
- All connectors, end plugs, 'O' rings, clips, brass fittings, collector straps and collector angle required for the installation are included with the collector kit. Suitable screws or anchors will be required to fix the collector straps to the rafters for a pitched roof installation.
- Screws to secure the collector straps and collector angle to the solar collector(s) must not be longer than 15 mm. Suitable screws are provided in the pipe kit.

ROOF ASSEMBLY OF SOLAR COLLECTORS

Numbers in parentheses refer to items in the diagrams on pages 20 and 22 (two solar collector installation) and pages 21 and 23 (three or four solar collector installation).

1. Select a suitable position for the solar collectors. Refer to “Solar Collector Location” on page 5.
2. **Pitched Roof Installation:** Determine the location of the collector angle(s) (1). If more than two solar collectors (17) are installed, locate the collector angle(s) (1) from the Collector Add On kit(s) adjacent to the first collector angle (1).

Tile Roof: Remove the tiles on the next row above the position of the collector angle (1) to expose the rafters. Hook two collector straps (2) to the collector angle (1). Ensure the collector angle (1) is horizontal. Once in position, fix the collector straps (2) to the rafters. Replace the tiles.

Metal Roof: Hook two collector straps (2) to the collector angle (1). Ensure the collector angle (1) is horizontal. Once in position, fix the collector straps (2) to the rafters, through the metal roofing material, using suitable screws or anchors. Care should be taken not to mark Colorbond or other metal roof sheet with a marking pen and to remove all swarf from the metal roof as these can cause deterioration of the metal roofing material.

Across Pitch or Against Pitch: Determine the location of the across pitch stand and flat roof stand or the against pitch stand and flat roof stand. Assemble and fix the stands to the roof, following the instructions provided with the stands.

3. **Flat Roof Installation:** Determine the location of the variable pitch stand(s). Assemble and fix the stand(s) to the roof, following the installation instructions provided with the stand(s).
4. Position the solar collectors (17) in the correct configuration with the lower ends seated in the collector angle (1).
5. For multiple solar collector installations, couple the solar collectors (17) together using:

Quick Connect Fittings: the connectors (3), ‘O’ rings (6), connector clips (7) and retaining clips (8) supplied in the collector kit. Refer to “Coupling Collector to Collector – Quick Connect” on page 12.

Screwed Fittings: the collector unions (3) and ‘O’ rings (6) supplied in the collector kit. Refer to “Coupling Collector to Collector – Screwed Fittings” on page 15.

DO NOT MODIFY THESE PARTS IN ANY WAY.

ROOF ASSEMBLY OF SOLAR COLLECTORS

6. Ensure the solar collectors (17) are well seated in the collector angle (1). Screw the collector angle (1) to the solar collectors (17) (two screws per collector), using the screws (13) provided.
7. **Pitched Roof Installation:** Position a collector strap (2) against the top end of each solar collector (17).

Tile Roof: Remove the tiles on the next row above the top edge of the solar collectors (17) to expose the rafters. Once in position, fix the collector straps (2) to the rafters. Replace the tiles. Screw the collector straps (2) to the solar collectors (17) using the screws (13) provided.

Metal Roof: Once in position, fix the collector straps (2) to the rafters, through the metal roofing material, using suitable screws or anchors. The collector straps (2) may be cut to a length of approximately 100 mm to retain the aesthetics of the installation. Screw the collector straps (2) to the solar collectors (17) using the screws (13) provided.

8. **Quick Connect Fittings:** Fit a connector (3) to the inlet of the solar collector array, sensor connector (4) (with hot sensor port) to the outlet of the solar collector array and end plugs (5) to the two remaining solar collector connections, using the 'O' rings (6), connector clips (7) and retaining clips (8) provided. Refer to "Connector, Sensor Connector, End Plug Assembly – Quick Connect" on page 12.

Screwed Fittings: Fit the connector (3) to the inlet of the solar collector array and the sensor connector (4) (with hot sensor port) to the outlet of the solar collector array using the 'O' rings (6) provided. Refer to "Coupling Cold and Hot Pipes to Collector – Screwed Fittings" on page 15. Fit the end plugs (5) to the two remaining solar collector connections using the 'O' rings (6) and blanking discs (7) provided. Refer to "End Plug Assembly – Screwed Fittings" on page 15.

DO NOT MODIFY THESE PARTS IN ANY WAY.

9. Insert the hot sensor probe (9) into the sensor connector (4), ensuring the 'O' ring is in position on the probe. Lock it into position with the locking washer and clip provided. Run the hot sensor lead down to the solar storage tank and connect to the solar control unit. An extension sensor lead is available if the hot sensor lead is not long enough to reach the solar control unit.
10. Install the solar cold pipe from the solar storage tank to the solar collectors (17) and the solar hot pipe from the solar collectors (17) to the solar storage tank. The solar hot and solar cold pipes should be a minimum DN15, but sized to suit the installation. Refer to "Pipe Lengths" on page 6, installation diagrams on pages 20 to 23, "Pipe Work Roughing In Dimensions" on page 18 and to the Warning on page 11.

ROOF ASSEMBLY OF SOLAR COLLECTORS

Notes:

- Penetrations through the roofing material must be:
 - at the high point of the roof tile or metal sheet;
 - made neatly and kept as small as practicable;
 - waterproofed upon installation of the solar hot and solar cold pipes.
- Exposed insulated pipe work between the solar collectors and the penetration through the roofing material should be kept to a minimum to maintain the aesthetics of the installation.

11. **Quick Connect Fittings:** Fit the brass quick connect adaptors (10) into the connector (3) and sensor connector (4) at the inlet and outlet of the solar collector array. Connect the solar cold pipe to the quick connect adaptor (10) at the inlet of the solar collectors (17) and the solar hot pipe to the quick connect adaptor (10) at the outlet of the solar collectors (17) using the compression nuts and olives provided. Refer to “Coupling Cold and Hot Pipes to Collector – Quick Connect” on page 13 and the installation diagrams on pages 20 and 21.

Screwed Fittings: Connect the solar cold pipe to the connector (10) at the inlet of the solar collectors (17) and the solar hot pipe to the sensor connector (4) at the outlet of the solar collectors (17) using the compression nuts and olives provided. Refer to “Coupling Cold and Hot Pipes to Collector – Screwed Fittings” on page 15 and the installation diagrams on pages 22 and 23.

12. At ground or floor level, adjacent to the site of the solar storage tank, attach the ‘Solar Cold Pipe’ label (16) to the insulation on the solar cold pipe to the solar collectors and the ‘Solar Hot Pipe’ label (15) to the insulation on the solar hot pipe from the solar collectors. Ensure the arrows on the labels are pointing in the correct direction of water flow.
13. Upon completion of the installation, turn on the cold water supply, bleed the air from the solar collectors and check the plumbing and connections for leaks. Refer to the Owners Guide and Installation instructions supplied with the solar storage tank for the procedure to bleed the solar collectors.

ROOF ASSEMBLY OF SOLAR COLLECTORS



WARNING: Plumber – Be Aware

- The solar hot and solar cold pipes between the solar storage tank and the solar collectors **MUST BE** of copper and fully insulated with closed cell polymer insulation or similar (minimum thickness 13 mm). The insulation must be weatherproof and UV resistant if exposed. All compression fittings must use brass or copper olives.

Note: Failure to observe this requirement may void the warranty for freeze damage.

The insulation is essential to assist in providing freeze protection, will offer corrosion protection to a metal roof against water runoff over the copper pipe, assist in avoiding accidental contact with the solar pipe work and also reduce pipe heat losses.

- The insulation must be **fitted up to the connections on both the solar collectors and the solar storage tank**, as very high temperature water can flow from the solar collectors to the solar storage tank under certain conditions.
- Plastic pipe **MUST NOT** be used, as it will not withstand the temperature and pressure of the water generated by the solar collectors under stagnation conditions. The solar collectors can generate extremely high water temperatures up to 150°C and high water pressure of 1000 kPa. Plastic pipe cannot withstand these temperatures and pressures, and **MUST NOT** be used. Failure of plastic pipe can lead to the release of high temperature water and cause severe water damage and flooding.
- There **must be a continuous fall** in the pipe work between the solar collectors and solar storage tank. The highest point of the solar cold pipe and solar hot pipe must be where they connect to the solar collectors, to avoid the possibility of air locks occurring in the system.

CONNECTION DETAILS

CONNECTOR, SENSOR CONNECTOR, END PLUG ASSEMBLY – QUICK CONNECT

Refer to installation diagram on page 20 for position and Detail B, Detail C and Detail D on page 14.

1. Lubricate the 'O' rings (6) with the lubricant provided.
2. Fit two 'O' rings (6), in the first two grooves, on the end of the collector pipe.
3. Firmly push the connector (3), sensor connector (4) or end plug (5) over the 'O' rings (6) until it seats.
4. Insert the connector clip (7) through the slot in the connector (3), sensor connector (4) or end plug (5) and push firmly into place. The connector clip (7) must engage in the third groove.
5. Attach the retaining clip (8) around the legs of the connector clip (7).

COUPLING COLLECTOR TO COLLECTOR – QUICK CONNECT

Refer to installation diagrams on pages 20 and 21 for position and Detail B on page 14.

1. Fit a connector (3) to each of the collector pipes of the first solar collector (17) to receive the second solar collector (refer to "Connector, Sensor Connector, End Plug Assembly – Quick Connect" on page 12).
2. Lubricate the 'O' rings (6) with the lubricant provided.
3. Fit two 'O' rings, in the first two grooves, on the end of the collector pipes of the second solar collector (17).
4. Position the second solar collector (17), inserting the top and bottom collector pipes into the connectors (3) on the first solar collector. Firmly push the solar collector (17) until the collector pipes seat inside the connectors (3).
5. Insert a connector clip (7) through the slot in each connector (3) and push firmly into place. The connector clip (7) must engage in the third groove. Attach a retaining clip (8) around the legs of each connector clip (7).

CONNECTION DETAILS

COUPLING COLD AND HOT PIPES TO COLLECTOR – QUICK CONNECT

Refer to installation diagram on page 20 for position and Detail A and Detail D on pages 13 and 14.

1. Fit a connector (3) to the end of the collector pipe to receive the solar cold pipe (refer to “Connector, Sensor Connector, End Plug Assembly – Quick Connect” on page 12).
2. Lubricate the ‘O’ rings (6) with the lubricant provided.
3. Fit two ‘O’ rings (6), in the first two grooves, on the end of the quick connect adaptor (10).
4. Insert the quick connect adaptor (10) into the connector (3) on the solar collector (17) and firmly push into position until it seats.
5. Insert the connector clip (7) through the slot in the connector (3) and push firmly into place. The connector clip (7) must engage in the third groove. Attach a retaining clip (8) around the legs of the connector clip (7).
6. Place the compression nut (11) and olive (12) over the end of the solar cold pipe. Position the cold pipe into the quick connect adaptor (10), seat the olive (12) and tighten the compression nut (11).
7. Repeat this procedure to couple the hot pipe to the solar collector (17) using the sensor connector (4).

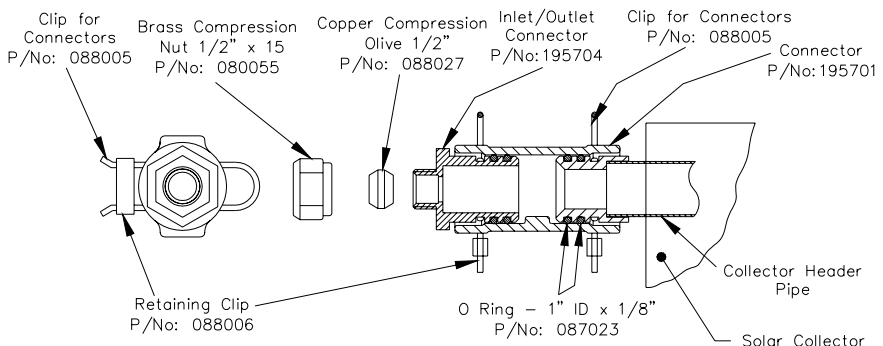

DETAIL A – CONNECTOR ASSEMBLY – QUICK CONNECT (WATER CONNECTION TO SOLAR COLLECTOR)

CONNECTION DETAILS

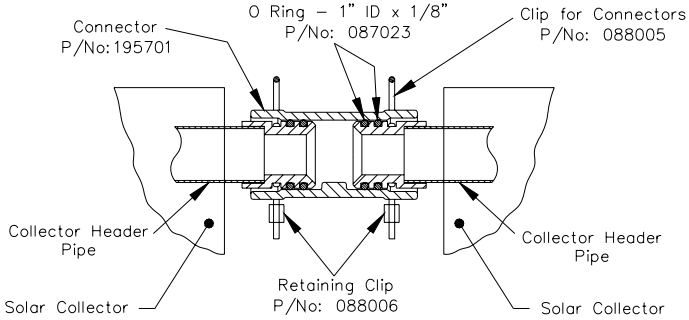

DETAIL B – CONNECTOR ASSEMBLY – QUICK CONNECT (BETWEEN SOLAR COLLECTORS)

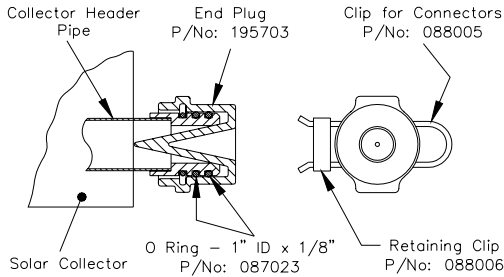

DETAIL C – END PLUG ASSEMBLY – QUICK CONNECT

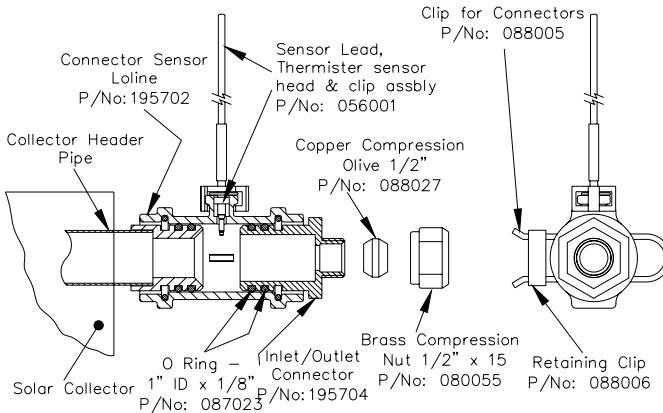

DETAIL D – SENSOR CONNECTOR ASSEMBLY – QUICK CONNECT

CONNECTION DETAILS

COUPLING COLLECTOR TO COLLECTOR – SCREWED FITTING

Refer to installation diagrams on pages 22 and 23 for position and Detail E on page 16.

1. Seat an 'O' ring (6) into each of the collector connections to be joined.
2. Fit a collector union (3) to each collector connection of the first solar collector (17) to receive the second solar collector.
3. Place the collector unions (3) into the collector connections on the second solar collector and screw in the unions until they seat firmly against the 'O' rings (6), applying medium pressure with a spanner to tighten.

END PLUG ASSEMBLY – SCREWED FITTING

Refer to installation diagram on page 22 for position and Detail F on page 16.

1. Seat an 'O' ring (6) into the collector connection.
2. Place a blanking disc (7) over the seated 'O' ring (6).
3. Place the end plug (5) into the collector connection and screw in until it seats firmly against the blanking disc (7), applying medium pressure with a spanner to tighten.

COUPLING COLD AND HOT PIPES TO COLLECTOR – SCREWED FITTING

Refer to installation diagram on page 22 for position and Detail G on page 17 and Detail H on page 17.

1. Seat an 'O' ring (6) into the collector connection.
2. Place the connector (10) into the collector connection and screw in the union until it seats firmly against the 'O' ring (6), applying medium pressure with a spanner to tighten.
3. Place the compression nut (11) and olive (12) over the end of the solar cold pipe. Position the cold pipe into the connector (10), seat the olive (12) and tighten the compression nut (11).
4. Repeat this procedure with the sensor connector (4) to couple the solar hot pipe to the solar collector (17).

CONNECTION DETAILS

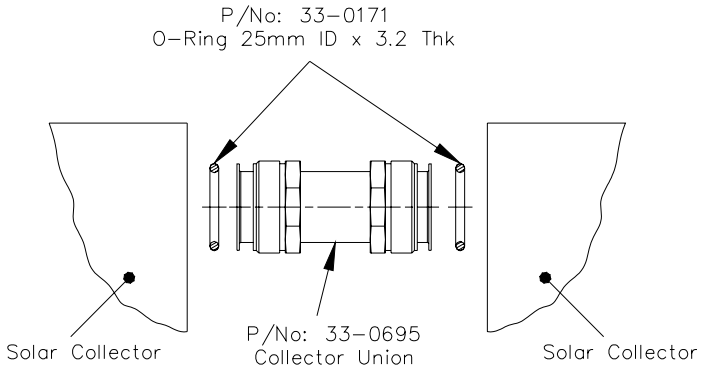

DETAIL E – COLLECTOR UNION ASSEMBLY – SCREWED FITTING

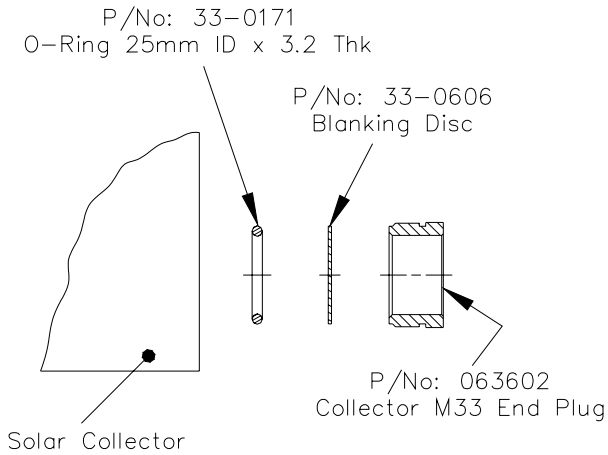

DETAIL F – END PLUG ASSEMBLY – SCREWED FITTING

CONNECTION DETAILS

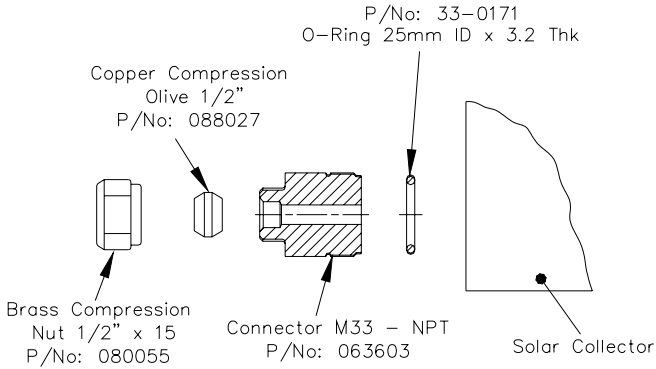

DETAIL G – CONNECTOR ASSEMBLY – SCREWED FITTING (WATER CONNECTION TO SOLAR COLLECTOR)

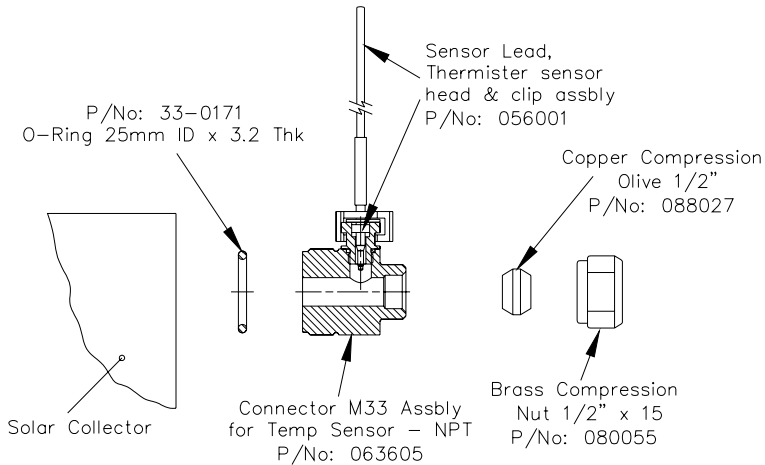

DETAIL H – SENSOR CONNECTOR ASSEMBLY – SCREWED FITTING

PIPE WORK ROUGHING IN DIMENSIONS

Refer to the diagrams for roughing in dimensions for pipe work to the solar collectors and to the solar storage tanks.

**Electric Boost
Solar Storage Tank**

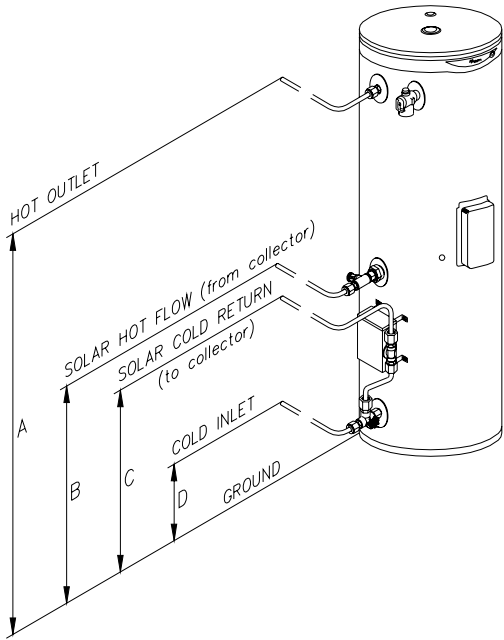

**Gas Boost
Solar Storage Tank**

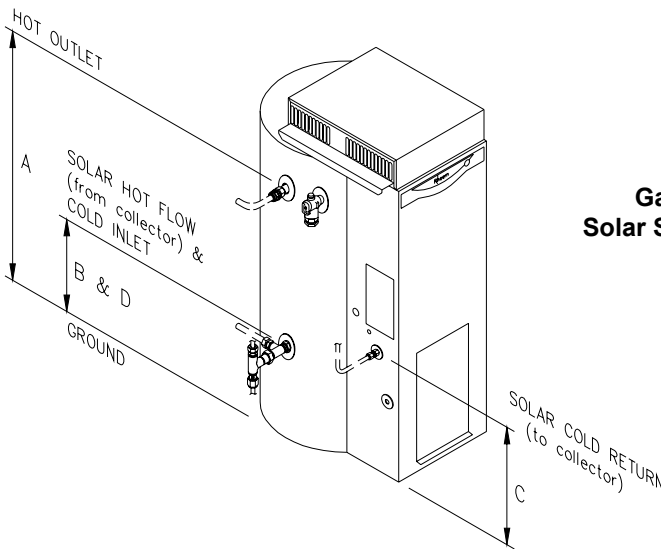

PIPE WORK ROUGHING IN DIMENSIONS

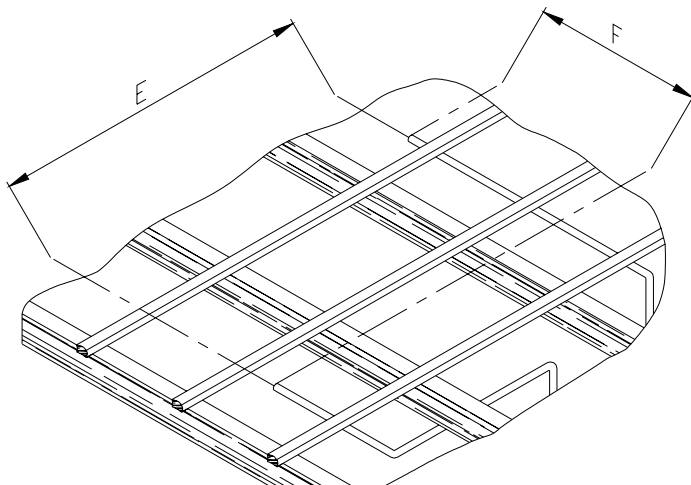

Solar Pipe Work Roughing In Dimensions

Pipe Work to Solar Storage Tank	A Hot Outlet	B Solar Hot Flow	C Solar Cold Return	D Cold Inlet
Electric Boost				
270	1190	572	373	73
340	1430	634	373	73
430	1600	498	381	81
Gas Boost				
260	1316	328	540	328

Pipe Work to Solar Collectors		
	E	F
1 Collector	1240	1880
2 Collectors	2360	1880
3 Collectors	3480	1880
4 Collectors	4600	1880

INSTALLATION – SOLAR COLLECTORS

INSTALLATION WITH QUICK CONNECT SOLAR COLLECTORS

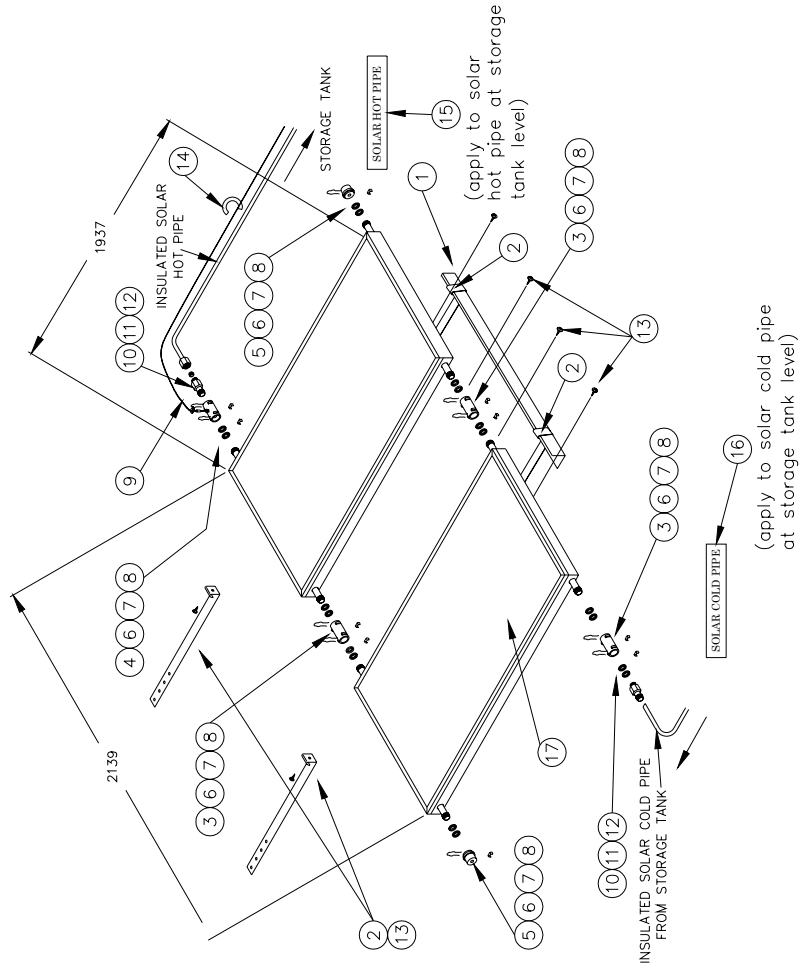

SUPPLIED IN COLLECTOR KIT (QUICK CONNECT FITTINGS) (299123)

1. Collector angle
2. Collector strap
3. Connector
4. Sensor connector
5. End plug
6. 'O' ring
7. Connector clip
8. Retaining clip
9. Hot sensor lead assembly
10. Quick connect adaptor
11. Compression nut
12. Compression olive
13. Screws
14. Cable tie
15. Label – solar hot pipe
16. Label – solar cold pipe

(Supplied separately)
17. Solar collector

INSTALLATION – SOLAR COLLECTORS

INSTALLATION – ADDITIONAL SOLAR COLLECTOR(S) – QUICK CONNECT FITTINGS

**SUPPLIED IN COLLECTOR
ADD ON KIT (QUICK
CONNECT FITTINGS)
(299125)**

1. Collector angle
2. Collector strap
3. Connector
6. 'O' ring
7. Connector clip
8. Retaining clip
13. Screws

(Supplied separately)
17. Solar collector

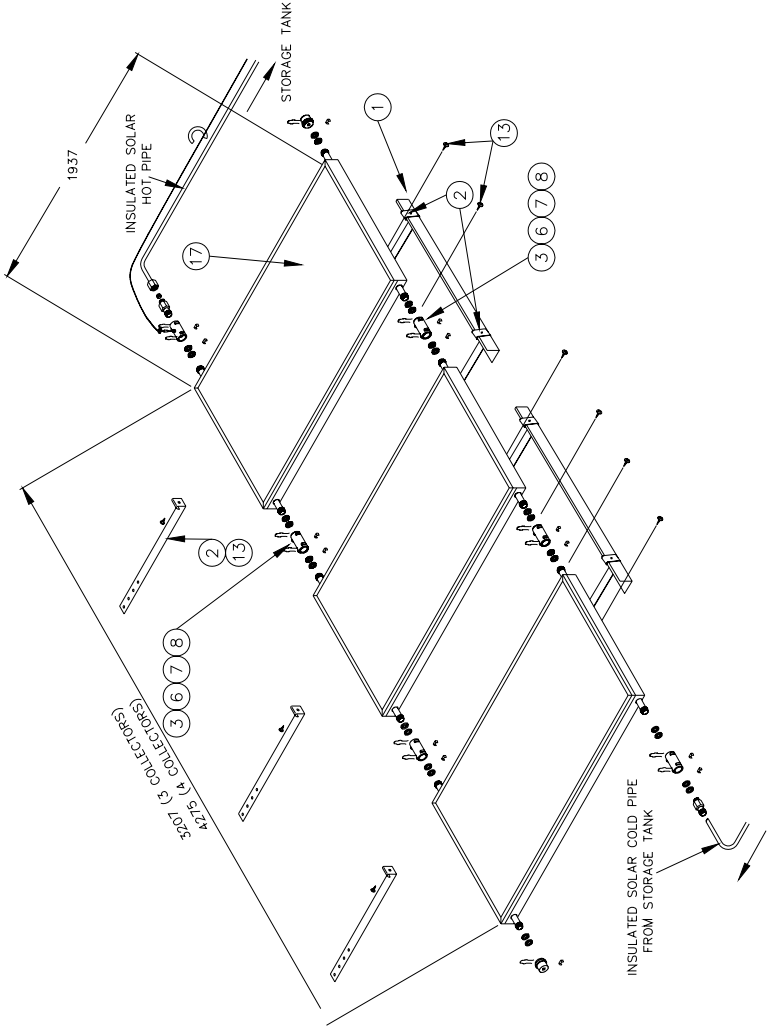

INSTALLATION – SOLAR COLLECTORS

INSTALLATION WITH SCREWED FITTING SOLAR COLLECTORS

SUPPLIED IN COLLECTOR KIT (SCREWED FITTINGS) (299139)

1. Collector angle
2. Collector strap
3. Collector union
4. Sensor connector
5. End plug
6. 'O' ring
7. Blanking disc
9. Hot sensor lead assembly
10. Connector
11. Compression nut
12. Compression olive
13. Screws
14. Cable tie
15. Label – solar hot pipe
16. Label – solar cold pipe

(Supplied separately)
17. Solar collector

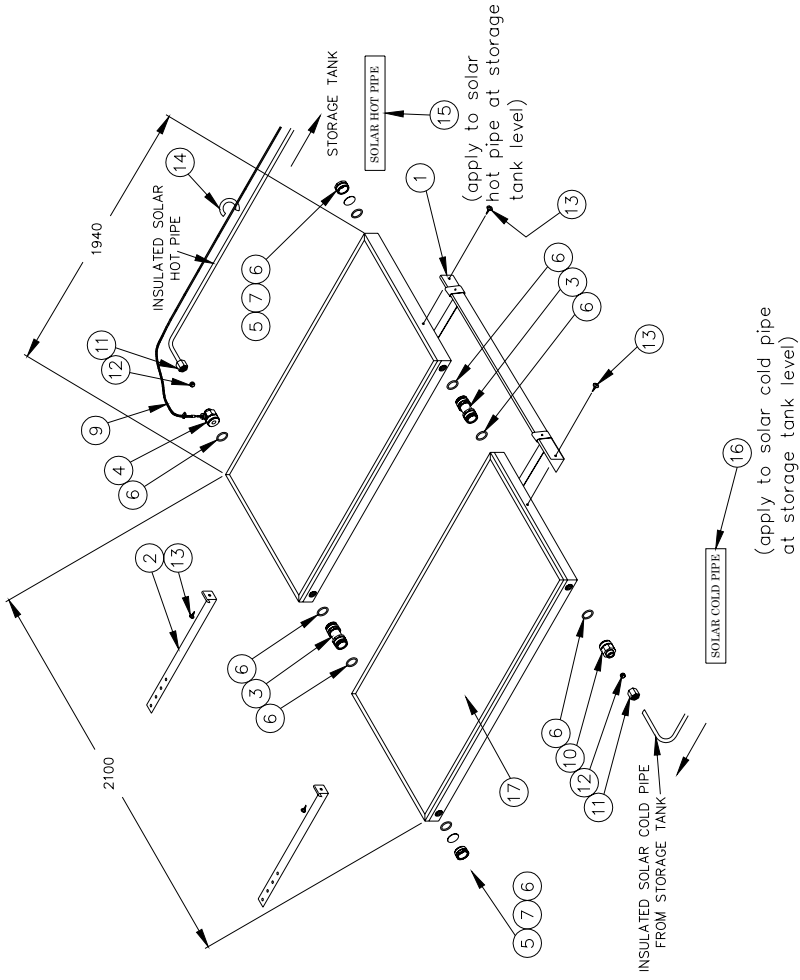

WARRANTY NOTE

The solar water heater and its components are covered by a comprehensive warranty. For full details, refer to the Owners Guide and Installation Instructions supplied with the solar storage tank.

Warranty Condition (5) and Warranty Exclusions (c), (d), (f), (g) and 2 of the water heater Warranty should be noted before commencing the installation of the solar collectors.

The term “water heater” used in the Warranty, Warranty Conditions and Warranty Exclusions means the Manufacturer supplied water heater(s), solar storage tank(s), solar collector(s), kit(s) and components.

WARRANTY CONDITIONS

5. Where the water heater is installed in a position that does not allow safe, ready access, the cost of accessing the site safely, including the cost of additional materials handling and /or safety equipment, shall be the owner's responsibility.

WARRANTY EXCLUSIONS

- c) Where the water heater or water heater component has failed directly or indirectly as a result of: excessive water pressure; excessive temperature and /or thermal input; blocked overflow /vent drain; corrosive atmosphere; ice formation in the pipe work to or from the water heater.
 - d) Where the solar water heater or solar water heater component has failed directly or indirectly as a result of ice formation in the water ways of a solar water heater system: without a freeze protection system; with a freeze protection system where the electricity supply has been switched off or has failed; (close coupled thermosyphon system) installed at an altitude more than 600 metres above sea level; (pumped system) installed at an altitude more than 800 metres above sea level; where the system has not been installed in accordance with the water heater installation instructions.
 - f) Repair and / or replacement of the water heater due to scale formation in the waterways or the effects of corrosive water when the water heater has been connected to a scaling or corrosive water supply as outlined in the Owner's Guide and Installation Instructions booklet.
 - g) Breakage of collector glass for any reason including hail damage. (We suggest that the collector glass be covered by your home insurance policy).
2. SUBJECT TO ANY STATUTORY PROVISIONS TO THE CONTRARY, THIS WARRANTY EXCLUDES ANY AND ALL CLAIMS FOR DAMAGE TO FURNITURE, CARPETS, WALLS, FOUNDATIONS OR ANY OTHER CONSEQUENTIAL LOSS EITHER DIRECTLY OR INDIRECTLY DUE TO LEAKAGE FROM THE WATER HEATER, OR DUE TO LEAKAGE FROM FITTINGS AND / OR PIPE WORK OF METAL, PLASTIC OR OTHER MATERIALS CAUSED BY WATER TEMPERATURE, WORKMANSHIP OR OTHER MODES OF FAILURE.

RHEEM AUSTRALIA PTY LTD
A.B.N. 21 098 823 511
www.rheem.com.au

FOR SERVICE TELEPHONE
131 031 AUSTRALIA
0800 657 335 NEW ZEALAND
or refer local Yellow Pages

Note: Every care has been taken to ensure accuracy in preparation of this publication. No liability can be accepted for any consequences, which may arise as a result of its application. 129870H