



OWNER'S MANUAL

Includes Installation Instructions

SOLAR WATER HEATERS





It is important you read the following safety information and warnings:

- This water heater must be installed, operated and maintained in accordance with the manufacturer's instructions for safety.
- This water heater is only intended to be operated by persons who have the experience or the knowledge and the capabilities to do so.
- This water heater is not intended to be operated by persons with reduced physical, sensory or mental capabilities i.e. the infirm and children. Children should be supervised to ensure they do not interfere with the water heater.
- This water heater has to be permanently connected to the water mains and not connected by a hose-set.
- The maximum inlet water pressure allowed for this device is 800kPa.
- This system must be fitted with a Pressure Relief Control. For details on pressure relief controls that can be used with this heater refer to the section "Pressure Relief Control" on Page 4.
- For instructions on connecting a temperature and pressure relief valve refer to Page 21. The discharge pipe of the temperature and pressure relief valve has to be installed in a downwards direction.
- If a temperature and pressure relief valve is fitted in your system, water may drip from its discharge pipe. This pipe must be left open to the atmosphere.
- If a temperature and pressure relief valve is fitted in your system, the valve is to be operated every six months to verify that it is not blocked. For instructions please refer to the section "Maintenance Requirements" on Page 7 of this booklet.
- If a vent pipe is fitted in your system water may at discharge high temperatures.
- The heater must be permanently fixed to a household roof or a concrete slab. For instructions on mounting refer to Pages 9 - 18.
- This system does not have freeze protection and is not suitable for installation in areas prone to frost or freeze conditions. For further details refer to the section "Frost/Freeze Protection" on Page 6.
- An electrical heating unit if fitted, uses 220 - 240 VAC electricity. The removal of the electrical access cover will expose live parts. It must only be removed by a suitably qualified person.
- If the power supply lead to the heater is damaged it must be replaced by a qualified person in order to avoid a hazard.
- The operation of the over-temperature cut-out on the thermostat indicates a possibly dangerous situation. If the over-temperature cut-out operates, the thermostat/safety cut-out must be replaced by a suitably qualified person.
- Care should be taken not to touch the pipe work connecting the solar storage tank and the solar collectors. Very high temperature hot water can be generated by the solar collectors under certain conditions and will flow through the pipe work from the solar collectors to the solar storage tank
- For instructions on how to drain the water heater refer to the section "To Empty the Water Heater" on Page 24 of this booklet.

HERE'S HOW IT WORKS

Solahart thermosiphon solar water heaters transfer heat absorbed from the sun by the solar collectors to the water storage tank through natural thermosiphon without the need for pumps or sensors.

The Solahart collectors absorb solar energy. The low-iron content solar glass allows more solar energy to pass through and be retained than conventional glass.

As potable water inside the collector heats up, it rises directly to the storage tank. As the heated potable water travels through to the storage tank, the cooler potable water returns to the collectors. This circulation repeats until all water in the storage tank is heated.

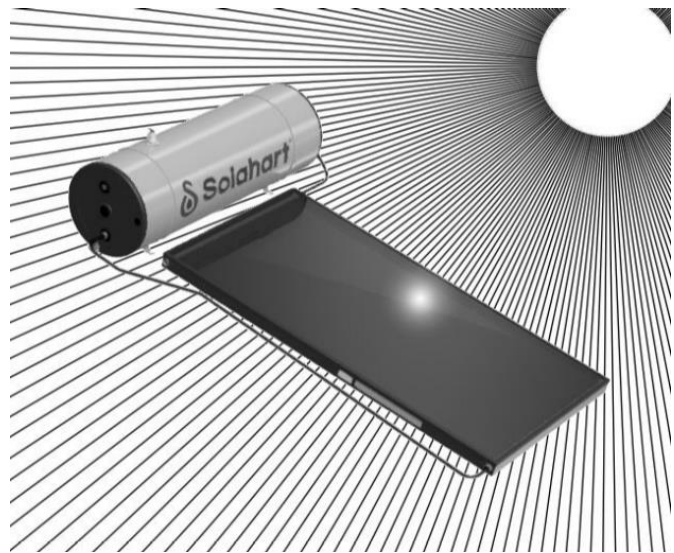
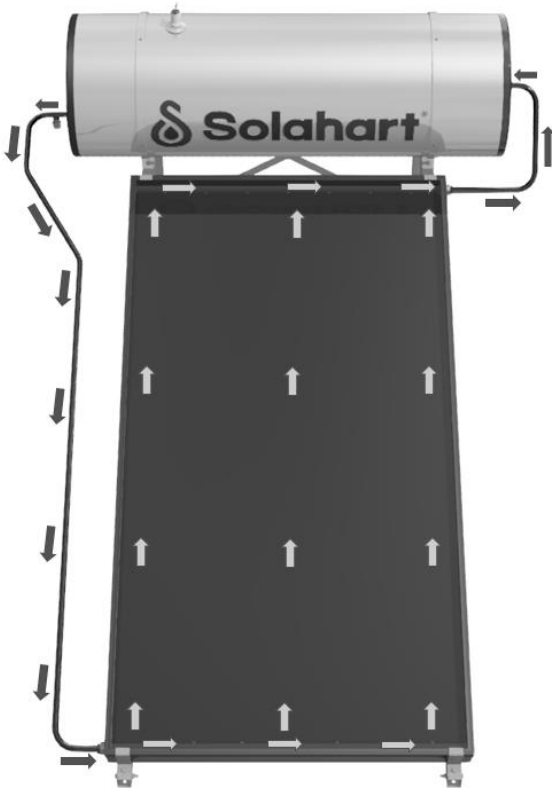

FACTS YOU SHOULD KNOW ABOUT YOUR SOLAHART WATER HEATER

Water Heater Application

This water heater is designed for the purpose of heating potable water. Its use in an application other than this may shorten its life.

Hotter Water Increases the Risk of Scald Injury

Under normal family use, the solar water heater should operate between 50°C and 60°C. However, the temperature can exceed this and under certain circumstances may be as high as 100°C. This can occur during periods of higher solar radiation or during long periods of reduced water usage. Extreme care should be taken in these circumstances.

⚠ Warning: This water heater can deliver water at temperatures which can cause scalding. Check the water temperature before use, such as when entering a shower or filling a bath or basin, to ensure it is suitable for the application and will not cause scald injury.

We recommend installing a suitable Tempering Valve to reduce the risk of scald injury.

Period of Reduced Usage or Holidays

If the water heater is left unused for two weeks or more, flammable hydrogen gas may accumulate in the water cylinder. To dissipate hydrogen gas safely, it is recommended that a sink hot tap be turned on for several minutes. Do not use a dishwasher, clothes washer or other appliance for this purpose. During this procedure there must be no smoking, open flames or any electrical appliance operating nearby. If hydrogen is discharged through the tap it will make an unusual sound like air escaping.

Unvented and Vented Systems

The Solahart thermosiphon solar water heater can be installed to operate as an Unvented System or a Vented System.

UNVENTED SYSTEMS

An unvented system requires an approved Temperature Pressure Relief (TPR) Valve connected to the pressure relief port of the tank. These systems can operate either with a mains pressure water supply or a gravity fed water supply.

VENTED SYSTEMS

When cold water to the tank is fed under gravity from a header tank, the solar water heater can be set up as a vented system. A vented system uses a Vent Pipe connected to the pressure relief port of the solar tank to allow safe expansion of water at elevated temperatures instead of a TPR valve. A Vent Pipe cannot be used with a mains pressure water supply. A TPR valve must be used instead (refer to unvented systems). For vent pipe details refer to Page 22.

Specifications

Storage Tank

Models	150RD18	150RD00
Storage Capacity	150 litres	
Dimensions	Length 1.4m; Diameter 461mm	
Weight	Empty tank 50kg; Tank Filled with Water 200kg	
Inner construction	Low carbon steel with vitreous enamel lining	
Anode	Magnesium with steel core	
Water and Pressure Relief Port connections	Rp 3/4	
Maximum Water Supply Pressure	800 kPa (applicable only when installed as an unvented system with a TPR valve)	
TPR valve setting	1,000 kPa/99°C (Optional)	
Heating Unit type	Immersion element with combination thermostat/safety cut-out	-
Supply Voltage	220 – 240 VAC, 50 – 60Hz	-
Rated Power	1.8 kW	-

Collector

Model	BPT20007
Aperture	1.87m ²
Dimensions	1.940m x 1.024m x 0.08m
Weight	40kg
Absorber	Painted Aluminium
Risers	Copper
Tray	0.45mm thick Prepainted steel
Insulation	38mm polyester blanket
Glass	3.2mm tempered low iron

System Configurations

STANDARD ROOF INSTALLATION		FLAT ROOF INSTALLATION	
150RD00/1BPT-W		150RD00/1BPT-F	
Tank - no element	1 x 150RD00	Tank - no element	1 x 150RD00
Collector	1 x BPT20007	Collector	1 x BPT20007
Installation Kit	1 x VN1000005	Flat Roof Frame Kit	1 x VN1000002
150RD18/1BPT-W		150RD18/1BPT-F	
Tank - 1.8kW element	1 x 150RD18	Tank - 1.8kW element	1 x 150RD18
Collector	1 x BPT20007	Collector	1 x BPT20007
Installation Kit	1 x VN1000005	Flat Roof Frame Kit	1 x VN1000002
150RD00/1BPT-WV		150RD00/1BPT-FV	
Tank - no element	1 x 150RD00	Tank - no element	1 x 150RD00
Collector	1 x BPT20007	Collector	1 x BPT20007
Installation Kit	1 x VN1000005	Flat Roof Frame Kit	1 x VN1000002
TPR Valve	1 x VN0262002K	TPR Valve	1 x VN0262002K
150RD18/1BPT-WV		150RD18/1BPT-FV	
Tank - 1.8kW element	1 x 150RD18	Tank - 1.8kW element	1 x 150RD18
Collector	1 x BPT20007	Collector	1 x BPT20007
Installation Kit	1 x VN1000005	Flat Roof Frame Kit	1 x VN1000002
TPR Valve	1 x VN0262002K	TPR Valve	1 x VN0262002K

Pressure Relief Control

For correct operation and safety, the pressure relief port of the tank must be fitted with one of the following Pressure Relief controls:

- Unvented Systems – Temperature and Pressure Relief (TPR) valve Part No. VN0262002K.
- Vented Systems - A Vent Pipe. Refer to Page 22 for connection details.

The pressure relief port of the tank is located at the top of the tank and is labelled as “PRESSURE RELIEF PORT”.

WARNING: The Pressure Relief port of the tank must not be plugged, restricted or plumbed by any means other than stipulated above. Blocking this port or unapproved plumbing connections to this port may lead to tank failures resulting in damage to property and personal injury, and will void the warranty.

TPR VALVE (UNVENTED SYSTEM)

This valve is fitted in the top of the water heater tank and is essential for the safe operation of an Unvented System.

WARNING: Part No. VN0262002K is the only approved TPR for this heater. The use of unapproved TPR valves may lead to tank failures resulting in damage to property and personal injury. The use of unapproved TPR valves will void the Solahart warranty.

It is possible for the valve to release a little water through the drain line during each heating period. This occurs as the water is heated and expands by approximately 1/50 of its volume. Continuous leakage of water from the valve and its drain line may indicate a problem with the water heater.

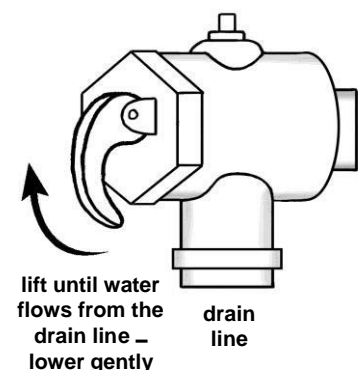

Warning: Never block the outlet of this valve or its drain line for any reason. The drain line must be left open to the atmosphere.

The easing lever on the temperature pressure relief valve should be operated once every six months. Refer to “[Minor Maintenance Every Six Months](#)” on [Page 7](#). **It is very important the lever is raised and lowered gently.**

DANGER: Failure to do this may result in the water heater cylinder failing, or under certain circumstances, exploding.

The temperature pressure relief valve should be replaced at intervals not exceeding 5 years, or more frequently in areas where there is a high incidence of water deposits.

Backup Electrical Heating

Primary heating of your hot water system will be from solar energy. The solar heating requires no operation by the user.

Systems fitted with a backup electrical heating unit can heat the water at times of low solar energy gain, such as during very cloudy or rainy weather, or during the colder months. The electrical heating unit also provides the means to inhibit the growth of bacteria in the water tank.

The backup electrical heating unit includes an immersion element, a thermostat that controls heating operation and an energy cut-out (ECO) for electrical safety. The element is positioned approximately at the middle position of the tank water volume. Electricity to the heating unit **MUST** be supplied via an Isolating Switch installed in the electrical switchboard.

The thermostat is factory preset to 60°C and has a maximum temperature setting of 70°C. When the water is below the thermostat setting, the heating element will turn on and heat the water volume above it. The heating element will turn off when the temperature of the water reaches the thermostat setting. If the water temperature drops below the setting again the heating element will re-activate.

Individual situations may require this setting to be altered. Only a suitably qualified person is permitted to adjust the thermostat temperature setting.

The overall performance and energy savings that you will obtain from your Solahart water heater will depend on your hot water usage pattern and the operation of the backup heating unit. A suitably rated timer control switch connected to the power supply can help maximize energy savings with a solar water heater fitted with a backup heating unit.

ENERGY CUT-OUT OPERATION

The ECO of the backup heating unit will de-energize the element should the temperature within the tank reach 83°C when the element is activated.

Should a fault occur with the Thermostat unit, the ECO will terminate electricity draw to the backup heating unit. If this occurs backup heating will not operate until the Thermostat/ECO assembly is replaced. The Thermostat/ECO assembly must be replaced by a suitably qualified person.

Temperature Stratification and Stabilization

During day time with normal solar gain a natural temperature gradient known as stratification occurs inside the tank, where the hotter water layers shift to the top and the colder layers settle at the bottom. This hot to cold variation inside the tank is highly desirable as the water delivered from the heater will come from the hottest part of the tank. The utilization of the hot water in this manner through the night and the following morning maximizes the opportunity of heat gain during daytime.

When there is no solar gain, the stratification described above gradually reduces as the hot water at the top of the storage cylinder transfers some of its heat to the cooler water in the lower section of the cylinder. Known as stabilization, this effect is often perceived as heat loss, but is actually the redistribution of stored heat more evenly over the entire contents of the storage tank. This heat is not lost to the system and is more prevalent when more hot water is used the night before and also in periods of lesser solar gain.

Water Supplies

This water heater must be installed in accordance with this advice to be covered by the Solahart warranty.

This water heater is manufactured to suit the water conditions of most public water supplies. Water supplies where the saturation index ranges between -1.0 and +0.4, and the level of total dissolved solids in the range of 40mg/L to 600 mg/L are considered suitable for this water heater.

However, there are some known water chemistries which can have detrimental effects on the water heater and its operation and / or life expectancy. If you are unsure of your water chemistry, you may be able to obtain information from your local water supply authority. This water heater should only be connected to a water supply which complies with these guidelines for the Solahart warranty to apply.

The vitreous enamel lined cylinder of the water heater is only covered by the Solahart warranty when the total dissolved solids (TDS) content in the water is from 40mg/L to 600 mg/L.

Anode Inspection and Replacement

The anode installed in this water heater will slowly dissipate whilst protecting the cylinder. The life of the cylinder may be extended by replacing the anode. The changing of an anode must be carried out by a qualified person.

For water supplies which are either softened or desalinated, or where the water supply may alternate between a water tank and a reticulated public supply or another supply, or where there is a variable supply (e.g. from a bore or public reticulated

supply from various water sources), the anode must be inspected (and replaced if there is any sign of depletion) within 5 years of its installation. For known very aggressive water supplies, the anode should be inspected within 3 years of its installation. Refer to your local Solahart Dealer.

For all water supplies, if the anode is not replaced during a major service (refer to “Major Service Every Five Years” on Page 7) then the maximum time after installation when the anode should be replaced for this water heater is 8 years.

Caution – Total Dissolved Solid (TDS)

If the water supply has a TDS greater than 600 mg/L there is the possibility the anode may become overactive and hydrogen gas, which is highly flammable, could accumulate in the top of the water heater during long periods of no use.

Under these conditions, the hydrogen must be vented safely by opening a hot tap and allowing the water to flow. Do not use any electrical appliances (automatic washing machines and dishwashers) for venting hydrogen gas. There should be no smoking or naked flame near the tap whilst it is turned on. Release of hydrogen gas is indicated by an unusual spurting of the water from the tap. Once the water runs freely, any hydrogen in the system will have been released.

Saturation Index

The saturation index is used as a measure of the water's corrosive or scaling properties.

In a corrosive water supply, the water can attack copper parts and cause them to fail including the heating unit and the collector. Where the saturation index is less than -1.0 , the water is very corrosive. If the saturation index is less than -1.0 the Solahart warranty does not apply.

In a scaling water supply calcium carbonate is deposited out of the water onto any hot metallic surface. Where the saturation index exceeds $+0.40$, the water is very scaling. If the saturation index exceeds $+0.40$, an expansion control valve must be fitted on the cold water line after the non-return valve to protect and for the Solahart warranty to apply to the temperature pressure relief valve and water heater cylinder.

Where the saturation index exceeds $+0.80$, the Solahart warranty does not apply to a standard watts density heating unit or a solar collector. A low watts density eating unit must be used for the Solahart warranty to apply to the heating unit.

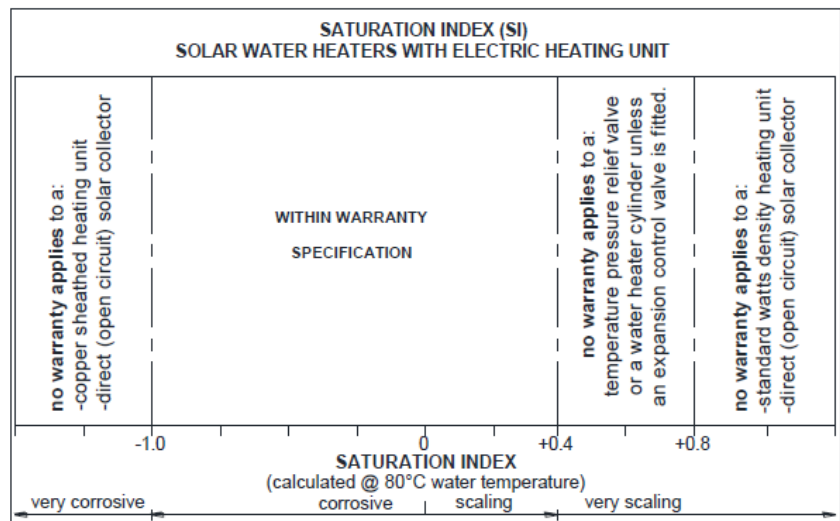

Solar collectors should be covered when the water heater is not intended to be used for more than two weeks to reduce the chance of scaling. Water which is scaling may be treated with a water softening device to reduce the saturation index of the water. Contact your local Solahart Dealer if a replacement heating unit is required.

Collector Glass Breakage

The Solahart warranty **DOES NOT** cover breakage of solar collector glass. It is recommended that the household insurance policy cover the collector glass and/or damage to the water heater, especially in cyclonic areas and in locations where severe hail is likely to occur. The collector glass is not offered as a replacement part. Should the solar collector require replacement, contact your local Solahart Dealer.

⚠ Warning: No attempt should be made to remove or replace broken collector glass.

Frost / Freeze Protection

This system does not have freeze protection and is not suitable for installation in areas prone to freeze conditions. Freeze conditions occur below 5°C (41°F). This system has **NO WARRANTY** for freeze damage. In areas that are prone to frost / freezing, a Closed Circuit system should be used and consult your Solahart Dealer for more advice.

MAINTENANCE REQUIREMENTS

Minor Maintenance Every Six Months – Applies to Unvented Systems Only

It is recommended minor maintenance on Unvented Systems (systems with TPR valves) be performed every six (6) months. Minor maintenance can be performed by the dwelling occupant.

The minor maintenance includes:

- 1) If accessible, operate the easing lever on the temperature pressure relief valve. It is very important you raise and lower the lever gently. Refer to “TPR Valve” on [Page 4](#).

⚠ Warning: Exercise care to avoid any splashing of water, as water discharged from the drain line will be hot. Stand clear of the drain line's point of discharge when operating the valve's lever.

If the temperature pressure relief valve is not readily accessible, contact your local Solahart Dealer.

- 2) If an expansion control valve is installed operate the easing lever on the expansion control valve. It is very important you raise and lower the lever gently.

If the expansion control valve is not readily accessible, contact your local Solahart Dealer.

Major Service Every Five Years – Applies to All Systems

It is recommended a major service be conducted on the water heater every five (5) years or to coincide with the anode inspection and / or replacement, whichever occurs sooner.

The major service can only be carried out by a qualified person. Contact your local Solahart dealer or authorized service representative. Only genuine replacement parts should be used on this water heater.

The major service addresses the following aspects:

- 1) Pressure Relief Control:
 - a. Unvented Systems - replace the TPR valve (Part No. VN0262002K), OR
 - b. Vented Systems - check the Vent Pipe for damages, excessive calcium build up. Replace Vent Pipe if necessary. Check any supports, ties or clamps holding the Vent Pipe in an upright position.
- 2) Where fitted, check the electric element for excessive calcium build up or corrosion. Replace if necessary.
- 3) Visually check the unit for any potential problems, e.g. broken glass, excessive dust build-up, shading etc.
- 4) Carefully inspect all connections.
- 5) Drain and flush out tank sediment build-up if required (see “[To Empty the Water Heater](#)” on [Page 24](#)).
- 6) Drain and flush collectors (see “[To Empty the Water Heater](#)” on [Page 24](#)).
- 7) Replace the anode.

Note: The major service and routine replacement of any components, such as the anode and relief valve(s), are not included in the Solahart warranty. A charge will be made for this work. Only genuine replacement parts should be used on this water heater.

If a temperature limiting device, water filter or a water softener are installed, their operation should be checked at this time. These checks are not covered within the major service. Neither a temperature limiting device, water filter nor a water softener is covered by the Solahart warranty.

SYSTEM DECOMMISSIONING

Decommissioning of the system should be undertaken by a suitably qualified person(s). All materials used in this product can be passed to your local material recycling centre for disposal - refer to local council regulations for details.

COLLECTOR CARE

Ensure the glass on your solar collectors is free of dust, salt spray or any other matter which may reduce the effectiveness of the solar collectors. Rainfall should keep the collector adequately clean. It is recommended that the collector glass be washed clean at least every three months should adequate rain not have fallen in this period. Collector glass can be hosed down or if the solar collectors are accessible, wash the collector glass with water and a soft brush when the solar collectors are cool, such as early in the morning. In extremely dusty areas, more frequent washing may be necessary.

Have any trees trimmed which may shade the solar collectors.

INSTALLATION INSTRUCTIONS

INSTALLATION MUST COMPLY WITH LOCAL ELECTRICAL AND PLUMBING CODES
--

This water heater must be installed:

- by a suitably qualified person, and
- in accordance with the installation instructions

WATER HEATER APPLICATION

This water heater is designed for the purpose of heating potable water. Its use in an application other than this may shorten its life.

LOCATION

The water heater should be located-

- for new installations, as close as possible to the most frequently used out water outlets; or
- for retrofit installations, as close as possible to the existing water heater.

The water heater must be installed in an area that is free of shade all year round. Ensure that trees do not shade the water heater, particularly in cooler climates.

NOTE: The element/anode end of the Tank should be placed no nearer than $\frac{3}{4}$ length of the Tank, to any wall or obstruction, so that the anode can be replaced during a service.

⚠ Warning: The water heater must be installed on an adequately supported area of roof. In cyclone areas additional mounting restraints are required. Obtain advice from a qualified building practitioner or structural engineer.

⚠ Warning: The tanks and collectors are heavy. Improper lifting techniques could result in personal injury during installation. It is the installer's responsibility to use only approved lifting and safety devices and techniques when lifting collectors and tanks on roofs.

⚠ Warning: Do not remove the solar collector packaging completely prior to the installation as the solar collector surface can become very hot. Remove only sufficient packaging material to enable the installation of the solar collectors

Refer to the Specifications section on Page 3 for the weight of the water heater. It is advisable that the weight of the water heater be braced to a load bearing wall. If in any doubt of the construction or the condition of the roof, obtain advice from a qualified building practitioner or structural engineer. The installer must ensure that the structural integrity of the roof is not compromised by the installation of the solar water heater.

Orientation of Solar Collectors

To help maximize system performance, solar collectors should be installed with an optimum orientation facing true south in the northern hemisphere or true north in the southern hemisphere. Always check for north or south using a compass.

The solar performance of a system reduces as the orientation of the collector moves away from the optimum orientation, resulting in lower solar energy collection. As the optimum orientation of solar collectors is not always practical or achievable, they may be installed facing a westerly or an easterly direction. A westerly orientation would be suitable if most of the hot water usage occurs in the afternoon.

Inclination of Solar Collectors

The collector requires a minimum inclination (slope) of 10° for the thermosiphon process to function correctly. In tropical regions solar collectors may be installed with an inclination between 10° and 30°.

For regions outside of the tropics solar collectors should be installed with an inclination closer to the local latitude angle to help optimize the system performance. This optimum inclination of solar collectors is not always practical or achievable. Solar collectors may be installed at the roof angle for simplicity of installation and appearance, but must never be less than 10°.

Mounting Options

Mounting frame options are available to allow the heater to be installed on a horizontal flat surface such as a concrete slab or a pitched (sloped) roof.

1. **Direct Roof Installation with Kit – VN1000005** – This option is designed to be suitable for standard roofs with slope angles between 10° and 30° covered with terracotta tiles or corrugated steel sheets.

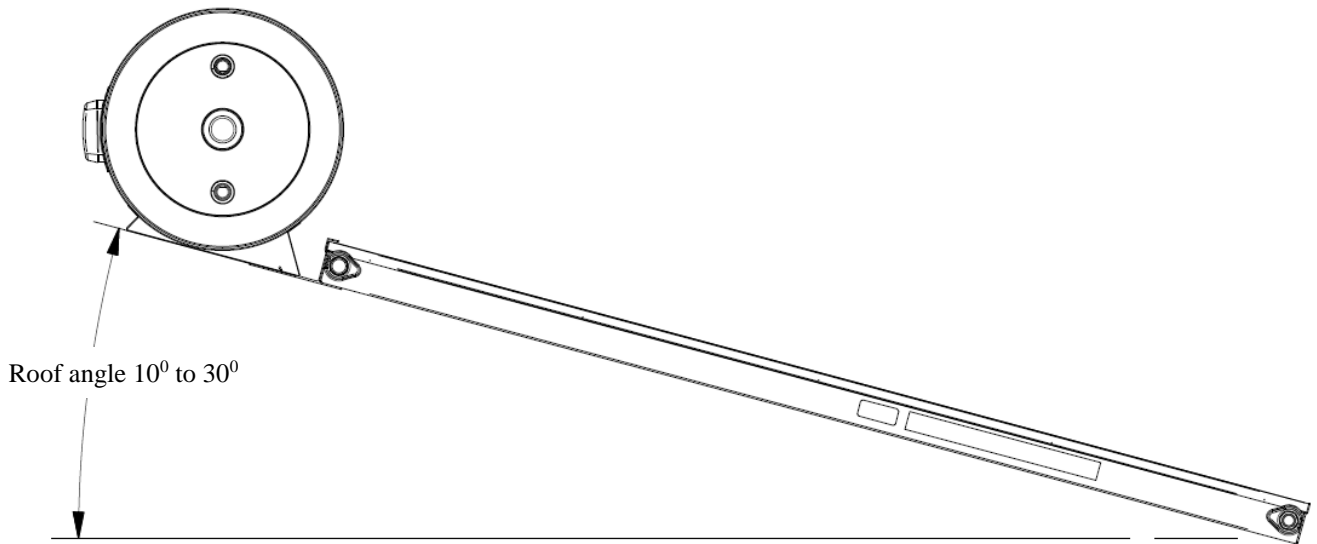

2. **Flat Roof Installation with Frame Kit – VN1000002** – This option is designed for horizontal flat roof installations. When installed the frame will provide a fixed pitch angle of 15° .

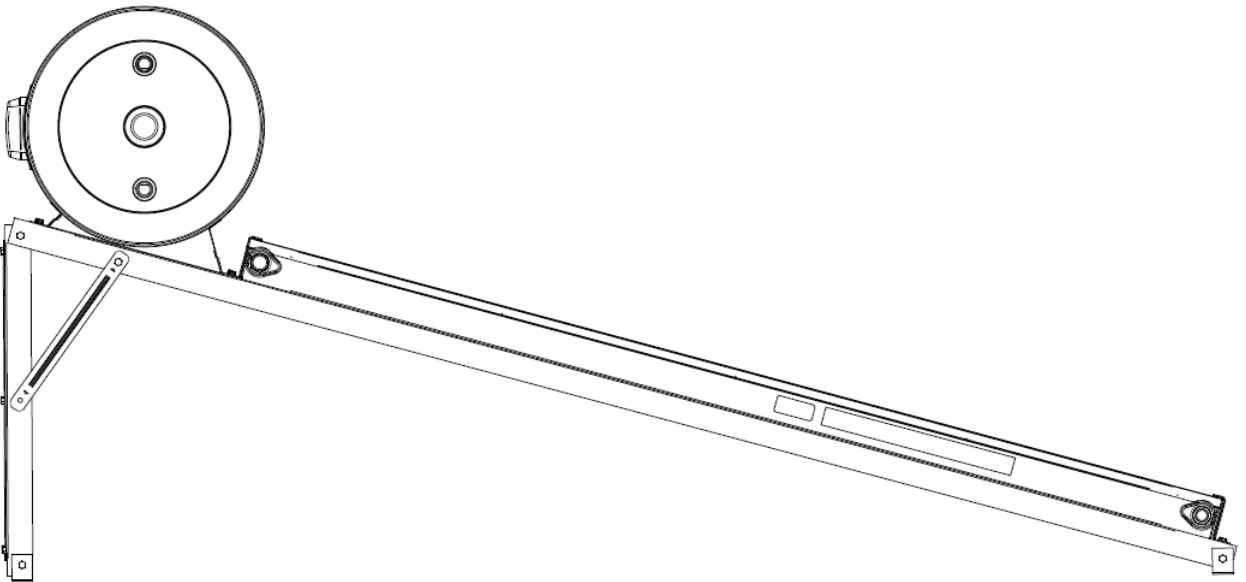

DIRECT ROOF INSTALLATION WITH KIT – VN1000005

Please note the following:

- The pitch of the roof on which the system is installed must not exceed 30° from a horizontal plane.
- Mounting with unapproved roof fixing components may cause water leakages and damage to the hot water system.
- The condition of the roof and specific location of the installation on the roof should be assessed by a qualified building practitioner or structural engineer before installing the system directly on a roof.
- The kit is not suitable for installations on slate roofing.

Kit Contents:



1 x Front Rail
Part No: VN1000512



4 x Tank Straps
Part No: 343064

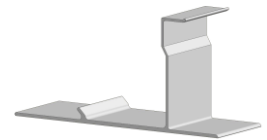

2 x Tank to Collector Spacers
Part No: 337144



1 x Cold Pipe
Part No: VN1000004



2 x Tank Nipples
Part No: VN0144202



2 x Collector Nipples
Part No: 344297



2 x Blanking Disc Nuts
Part No: 330600



4 x O-rings
Part No: 330171



2 x Blanking Discs
Part No: 330606

Roof fixing instructions:

1. Determine the position of the tank ensuring that the base of the tank is positioned above a roof batten. Refer to Page 8 of the Owner's Manual for the location, orientation and inclination of the Solar Hot Water Heater.

If the installation is on a tile roof, ensure the front of the tank base is toward the nose of a row of tiles and the rear of the tank base is seated over the nose of the tiles on the next row behind.

After deciding the tank position, the Front Rail supplied in the kit must be positioned approximately 1980mm down from the tank base as shown below.

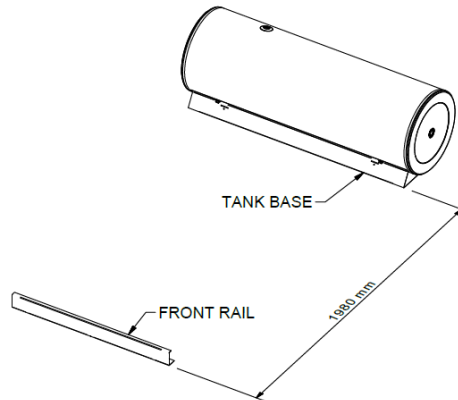

2. The Front Rail must be permanently fixed to the roof using two of the stainless-steel straps supplied in the kit.

To attach the straps to the Front Rail, slide the short section of each strap through the relevant slot from the inside of the Front Rail as shown below.

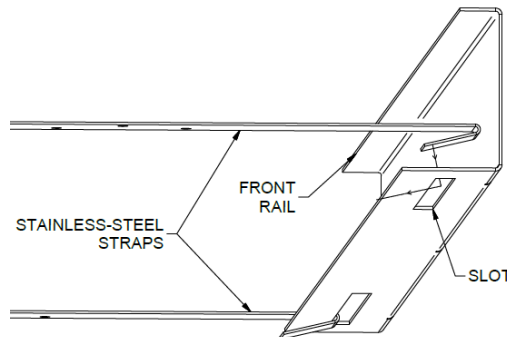

For optimum thermosiphon performance the Front Rail right corner should be positioned upwards along roof surface relative to the left corner by about 12 – 15mm.

- Tile Roof Fixing: Remove the tiles on the next row above the position of the Front Rail to expose the rafters. Once in position, fix the ends of the straps to the rafters using suitable fasteners and replace the tiles
 - Metal Roof Fixing: Fix the ends of the straps to the rafters, through the metal roofing material, using suitable fasteners.
3. Slide the collector into the opening of Front Rail making sure the bottom end of the collector is resting against the up-right face of the Front Rail as shown.

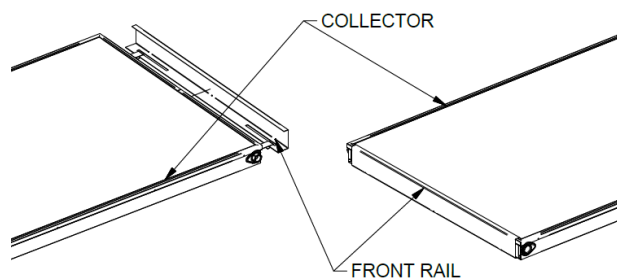

4. Locate the two Tank to Collector Spacers provided in the Kit against the top end of the collector as shown.

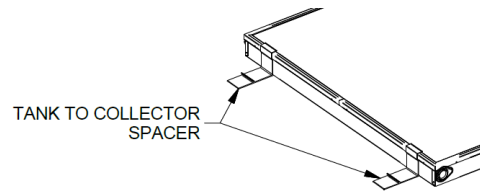

5. Place the tank above the Tank to Collector Spacers such that the rear tab of each spacer is in contact with the edge of the two rectangular slots of the tank base. Ensure the tank is centralized about the collector.

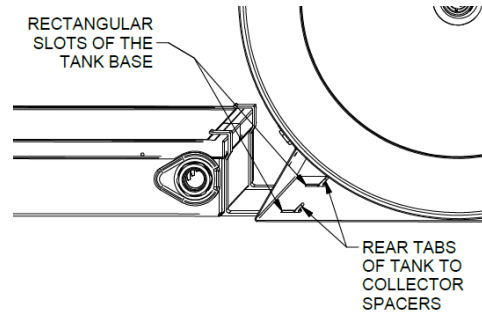

6. Make the appropriate connections of the hot pipe, cold pipe and closed ends of the collector as per the instructions supplied in Page 19 and Page 20 of the Owner's Manual.
7. Next the tank must be permanently fixed to the roof using the two remaining straps supplied in the Kit.

Attach the tank straps to the louvers underneath of the tank base as shown below.

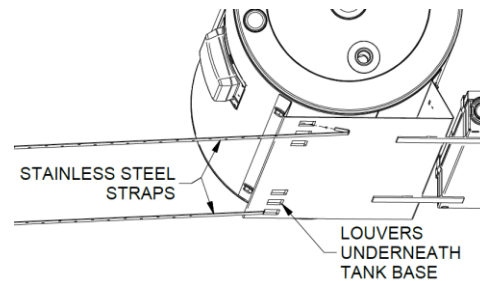

- **Tile Roof Fixing:** Remove the tiles on the next row above the position of the tank to expose the rafters. Once in position, fix the ends of the straps to the rafters using suitable fasteners and replace the tiles
- **Metal Roof Fixing:** Fix the ends of the straps to the rafters, through the metal roofing material, using suitable fasteners.

INSTALLATION ON A CONCRETE SLAB OR FLAT ROOF USING VN100002 FRAME KIT

COMPONENTS SUPPLIED IN THE KIT BOX



2 x Vertical Rails
Part No: VN1000503

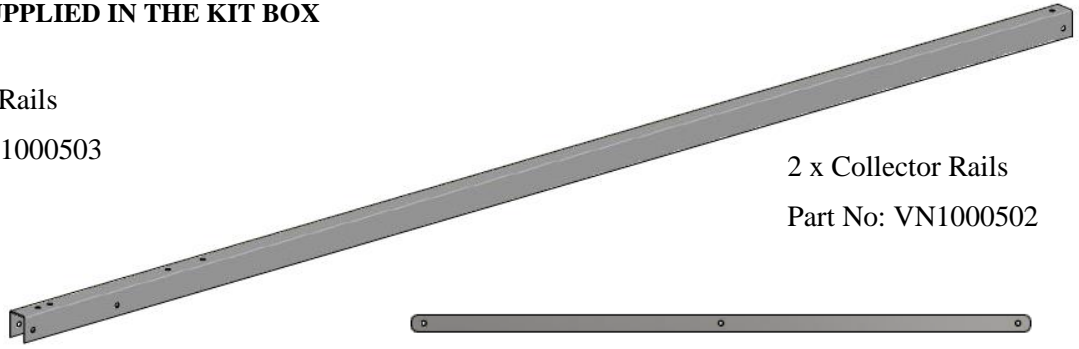

2 x Collector Rails
Part No: VN1000502



2 x Cross Braces
Part No: VN1000504



2 x Side Braces
Part No: VN1000513



4 x Base Channels
Part No: VN1000509



6 x Tube Spacers
Part No: VN0016001

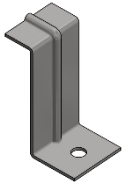

2 x Collector Clamps
Part No: VN1000506

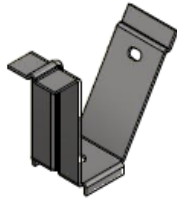

2 x Tank to Collector Spacers
Part No: VN1000511



2 x Back Tank Clamps
Part No: VN1000514



4 x M6.3x19mm Screws
Part No: VN0100206



11 x M8x25mm Bolts
Part No: 209110



6 x M8x60mm Bolts
Part No: 209112



17 x M8 Nuts
Part No: 209103



2 x Flat Washers
Part No: 209103



1 x Cold Pipe
Part No: VN1000004



2 x Tank Nipples
Part No: VN0144202



2 x Collector Nipples
Part No: 344297



2 x Blanking Disc Nuts
Part No: 330600



4 x O-rings
Part No: 330171



2 x Blanking Discs
Part No: 330606

Frame Assembly Instructions

Please note the following:

- This frame has not been rated for cyclonic conditions.
 - The condition of the roof and specific location of the installation on the roof should be assessed by a qualified building practitioner or structural engineer before installing this frame.
 - The four Base Channels supplied in the kit box must be permanently fixed to the concrete slab using M10 concrete fasteners.
 - Concrete fasteners must be selected considering the construction of the structure on which the frame is mounted and wind conditions specific to the installed location. The kit does not include the fasteners for fixing the frame to the roof.
 - All fasteners supplied with this kit must be tightened to a torque between 27-32Nm when assembling the frame.
1. Fix the four Base Channels supplied in the kit box permanently to the concrete slab using M10 concrete fasteners located on the corners of a 2318mm x 922mm rectangle as shown below.

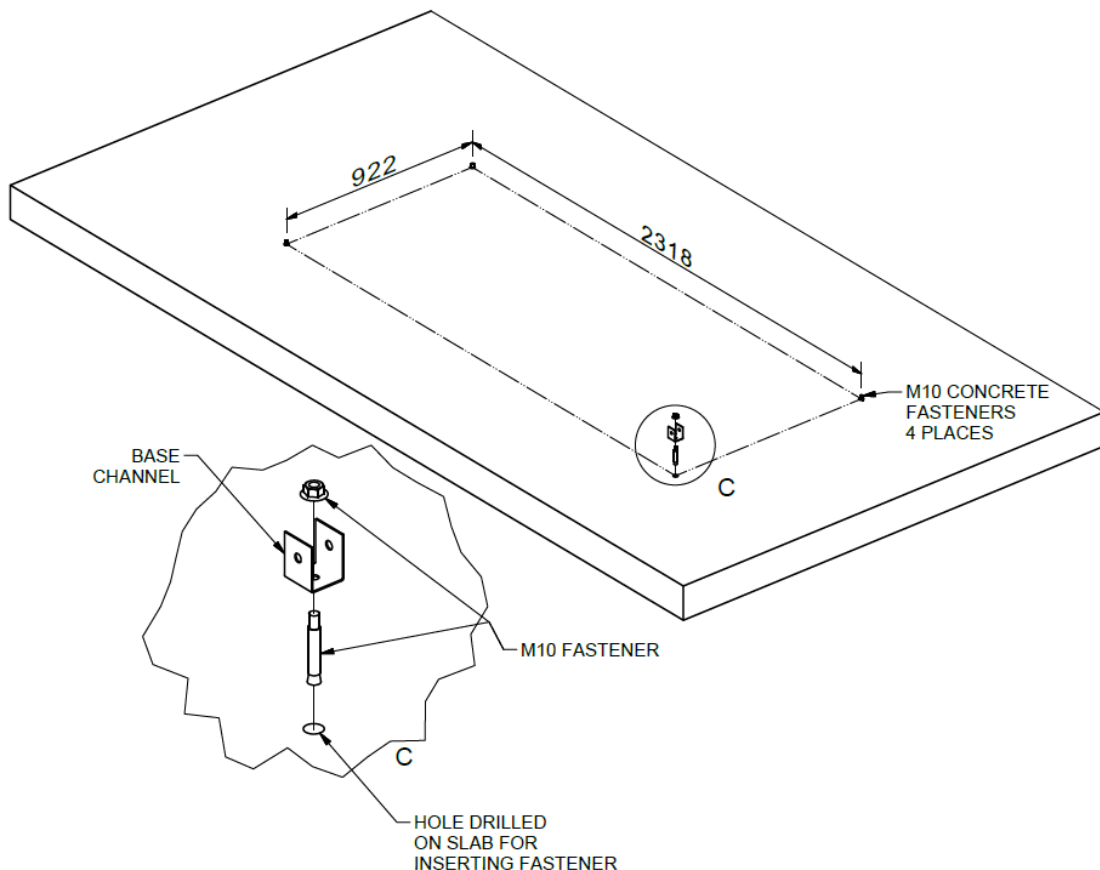
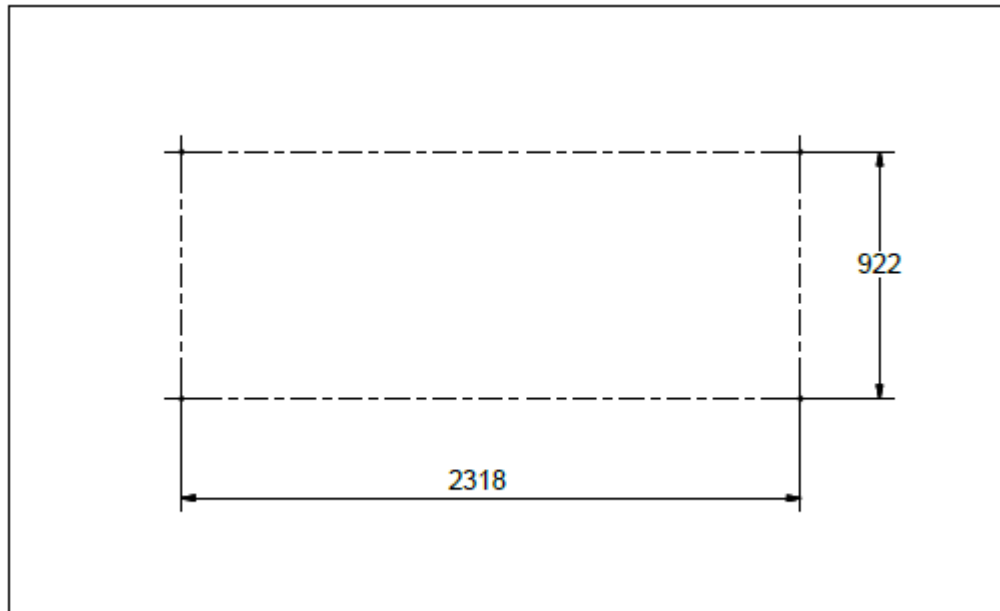

2. After fixing the Base Channels to the concrete slab assemble one side of the frame as instructed in the following sub-sections:

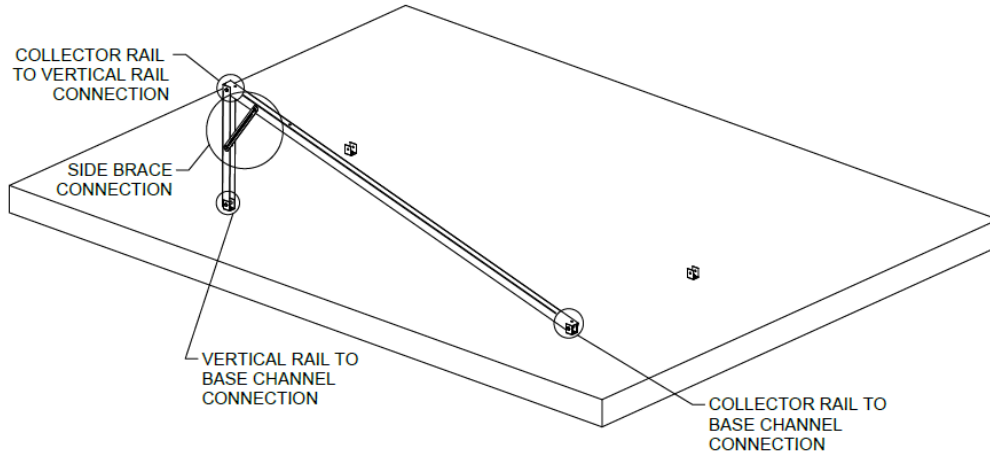

- 2.1 Connect the Collector Rail to the Base Channel as shown:

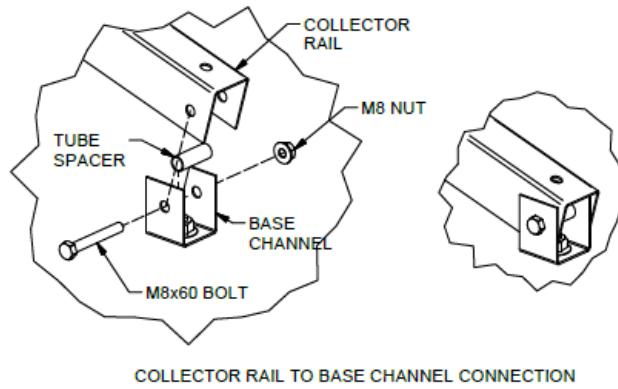

- 2.2 Connect the Vertical Rail to the Base Channel as shown:

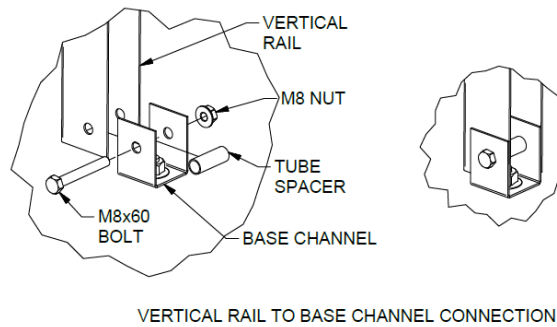

- 2.3 Connect the Vertical Rail to the Collector Rail as shown:

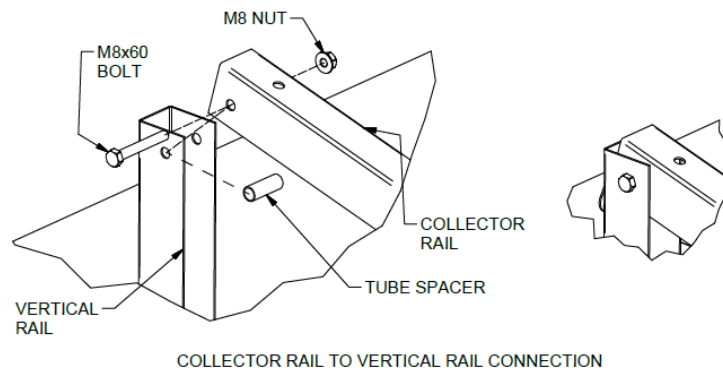

2.4 Connect the Side Brace the to the Collector Rail and Vertical Rail as shown:

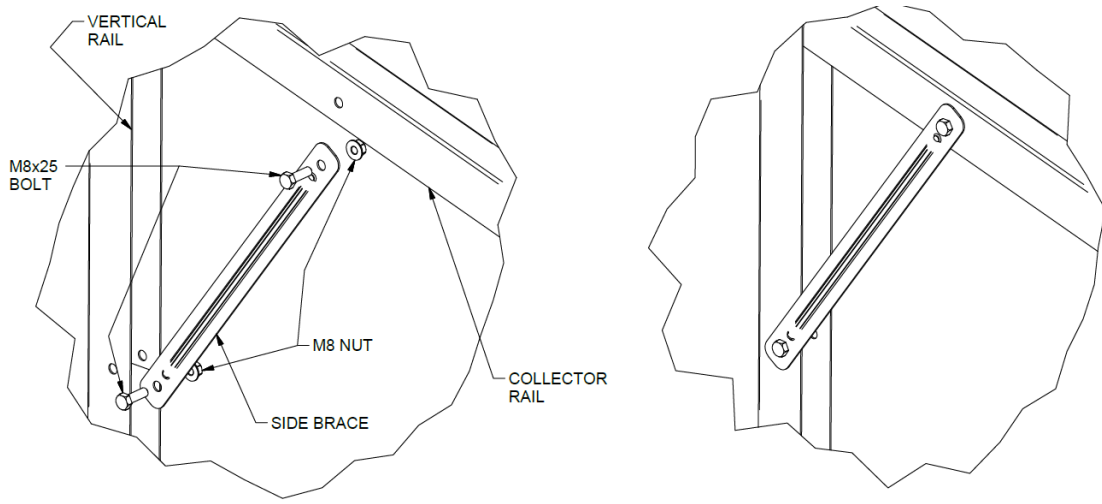

SIDE BRACE CONNECTION

3. Repeat the same process to assemble the other side of the frame interconnecting the remaining Base Channels, Collector Rail, Vertical Rail and Side Brace as shown:

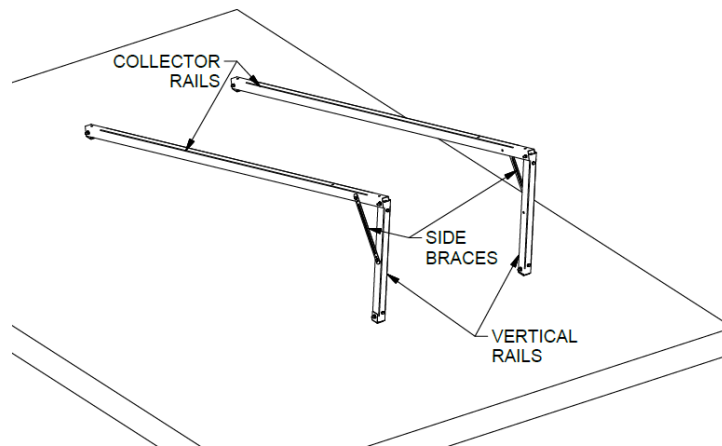

4. Connect the two cross braces to the Two Vertical Channels as shown:

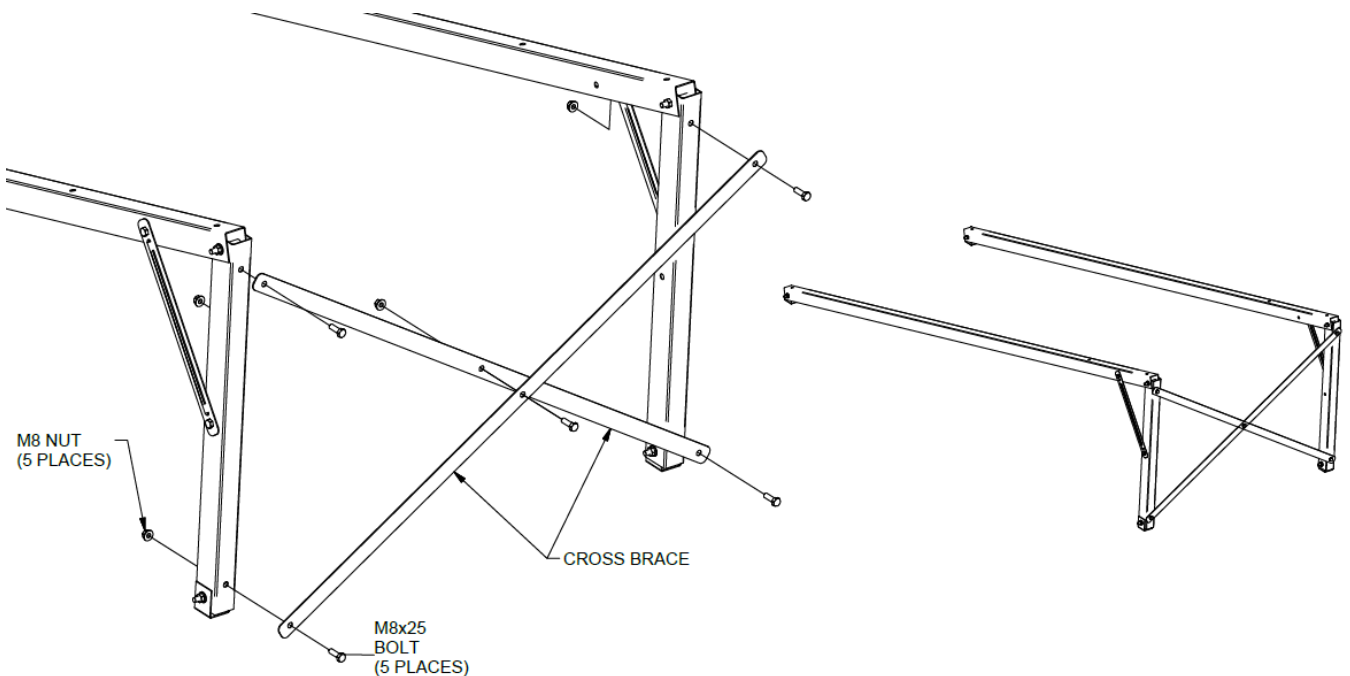

COLLECTOR AND TANK INSTALLATION ON THE FRAME

1. Install the Collector Clamps using M8x25mm Bolts and M8 Nuts at the two locations near the front end of the frame as shown.

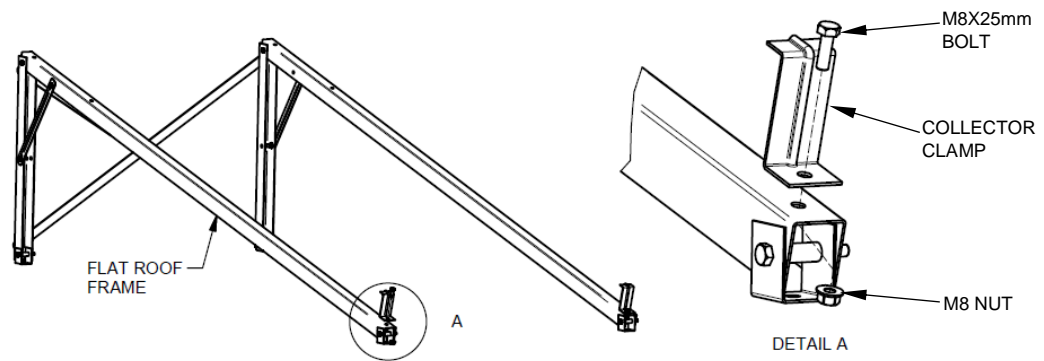

2. Place the Collector centrally on the Collector Rails with the front of the Collector resting against the Collector Clamps.

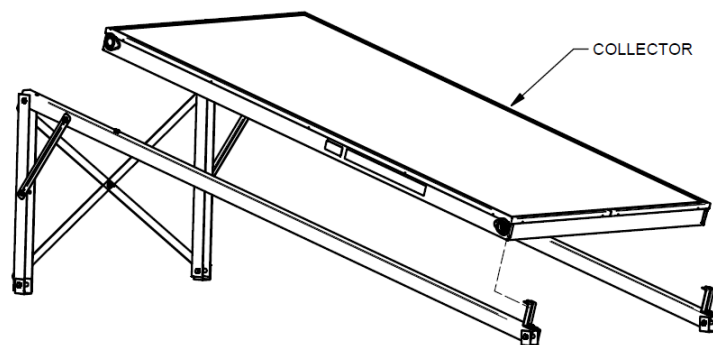

3. Rest the Tank centrally on the Collector Rails behind the Collector.

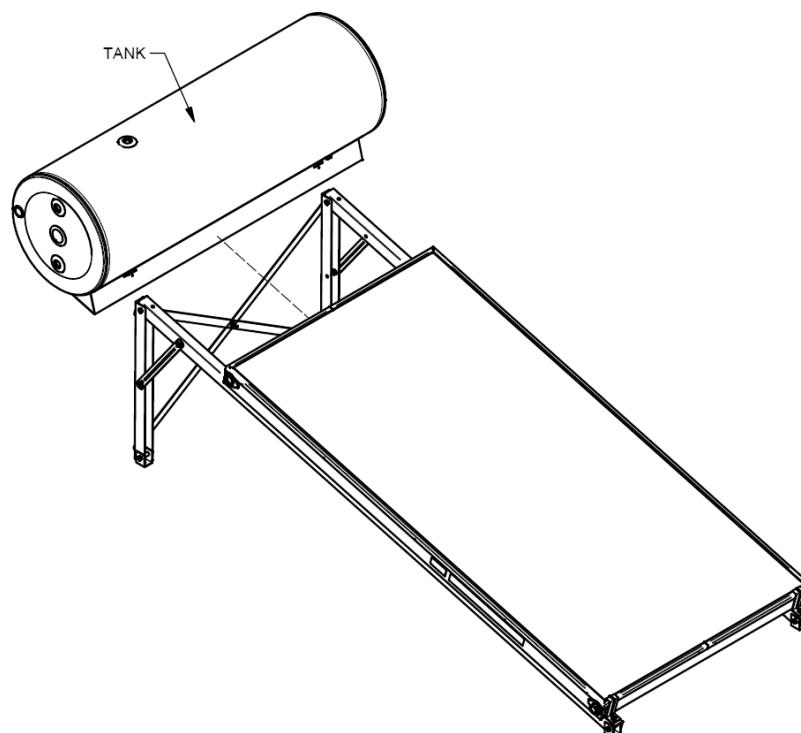

4. Attach the Tank to Collector Spacers to the tank by inserting the locking tabs to the rectangular slots on the front face of the tank base as shown. Then secure the Tank to Collector Spacers to the Tank using two of M6.3x 19mm screws. Finally secure the Tank to Collector Spacers to the frame using two pairs of the M8x25 Bolts and M8 Nuts.

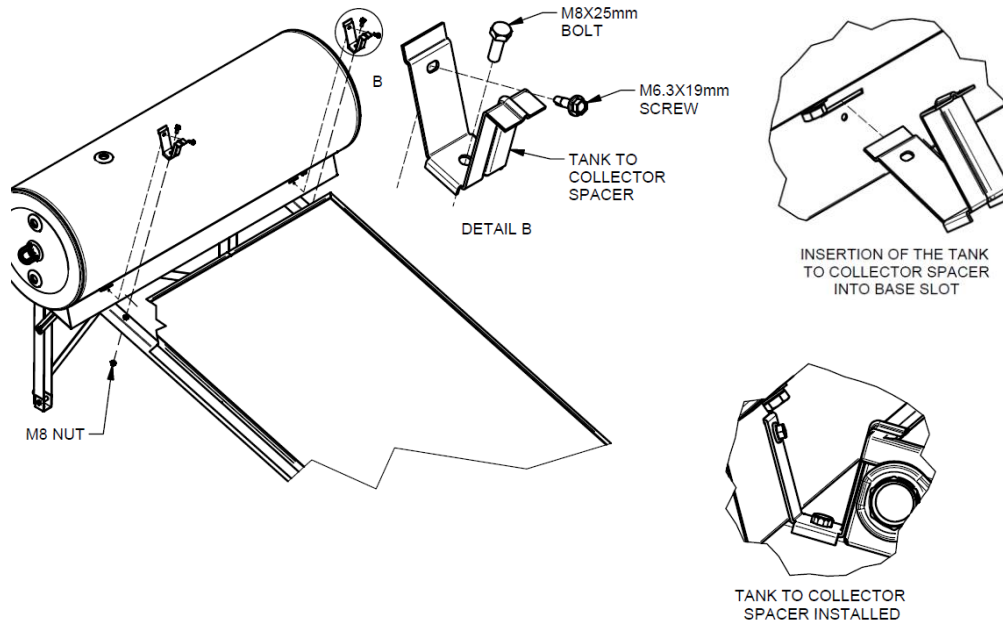



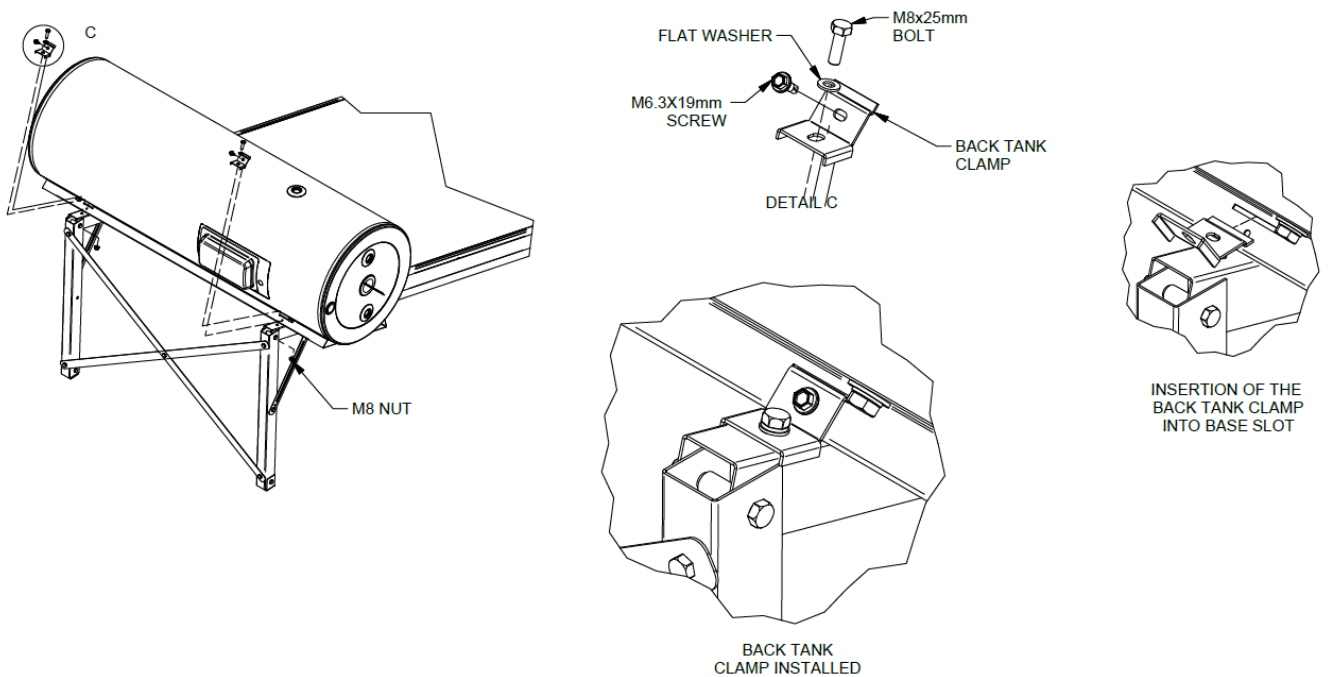

5. Attach the Back-Tank Clamps to the Tank by inserting the locking tabs to the rectangular slots on the back face of the tank base as shown. Then secure the Back-Tank Clamps to the Tank using two of M6.3x 19mm screws. Finally secure the Back-Tank Clamps to the Collector Rails using the M8x25mm Bolts, flat washers and M8 Nuts as shown.



THE PIPE KIT CONNECTION

Fittings required are as shown (supplied with the kit):

Image	Part Number	Description	Quantity
	VN0144202	NIPPLE COMPRESSION R20M-G20F DR BRASS	2
	34-4297	ADAPTOR M33 (M) TO G3/4 CONETITE (F) DR VERSION	2
	33-0171	O' RING 25MM DIA	4
	33-0600	GLAND NUT L COLLECTOR M33 M	2
	33-0606	BLANKING DISC L	2

The following parts are also required:

- VN1000003 – HOT PIPE ASSEMBLY SH 150L SOLAR DIRECT – supplied in the tank carton
- VN1000004 – COLD PIPE ASSEMBLY SH 150L SOLAR DIRECT – supplied in the kit carton

Warning: Do not over-tighten the rubber O-rings. The O-rings can get damaged causing leakage if over-tightened.

1. Connect the cold pipe between the port labelled as “SOLAR FLOW” on the tank and the collector as shown:

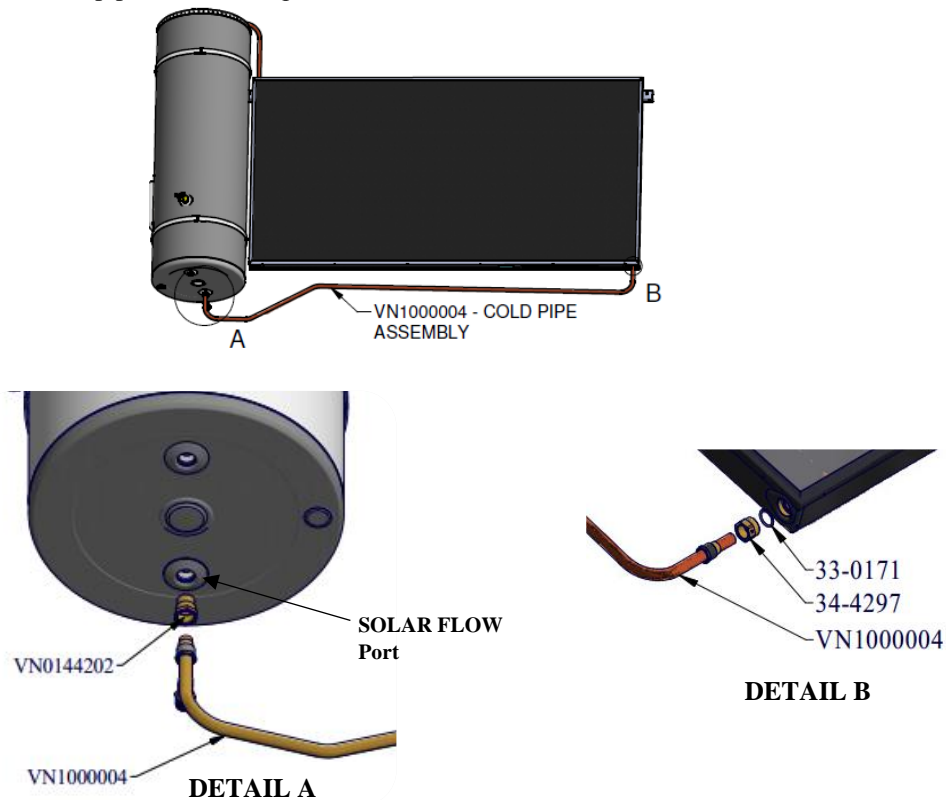

2. Connect the hot pipe between the port labelled as “SOLAR RETURN” on the tank and the collector as shown:

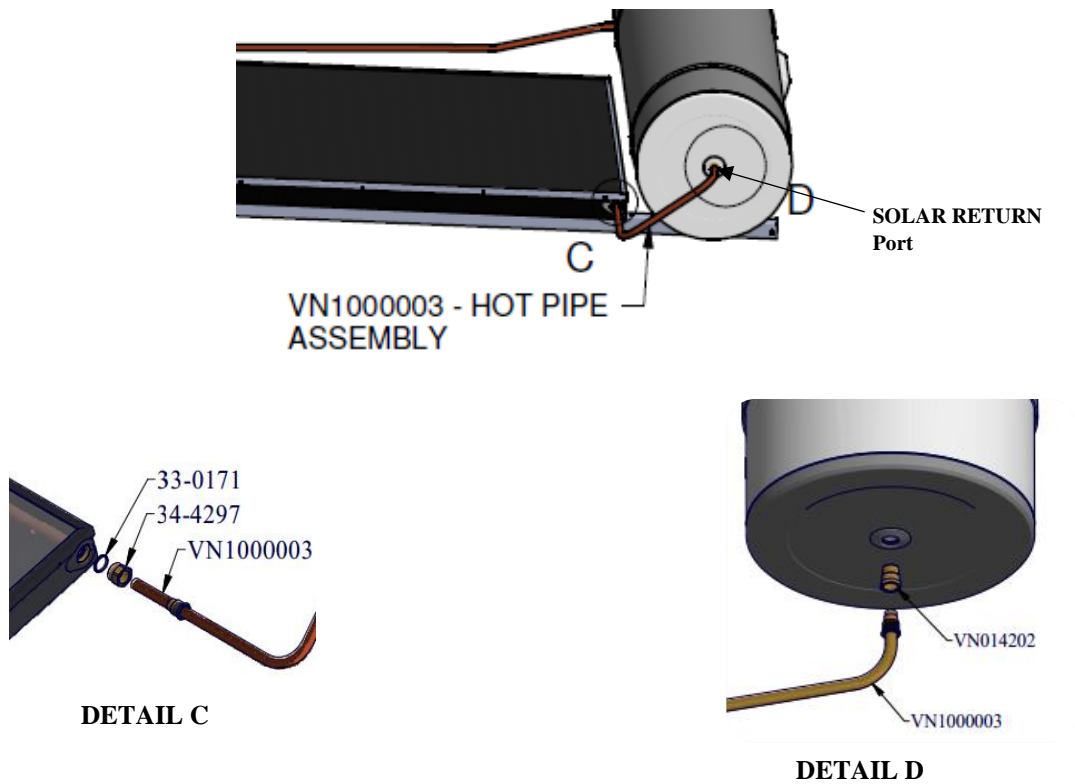

3. Close the two open ends of the collector. When closing off each open end of the collector, first insert the 33-0171 O-Ring, followed by 33-0606 Blanking Disk. Finally screw in and tighten the 33-0600 Gland Nut with a spanner.

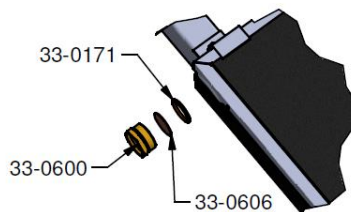

Plumbing

This water heater is intended to be permanently connected to the cold water supply and not connected by a hose-set. All plumbing work must be carried out by a suitably qualified person. All installations are to be in accordance with national and local codes and regulatory authority requirements applicable in your area.

Note that any pipes that are required to enter to the house either through a wall, ceiling cavity or roof need to be fully sealed and waterproofed and should comply with local building codes and practices.

The maximum allowed water supply pressure to the water heater is 800kPa. If the supply pressure exceeds this limit, Solahart advises the limiting of water pressure to 800kPa with a pressure limiting valve to suit this solar water heater.

If the water heater is supplied with water from a tank supply and a pressure pump is not installed, then the bottom of the supply tank must be at least 1m above the plumbing and the tank of the solar hot water system, except the vent pipe.

COLD SUPPLY CONNECTION

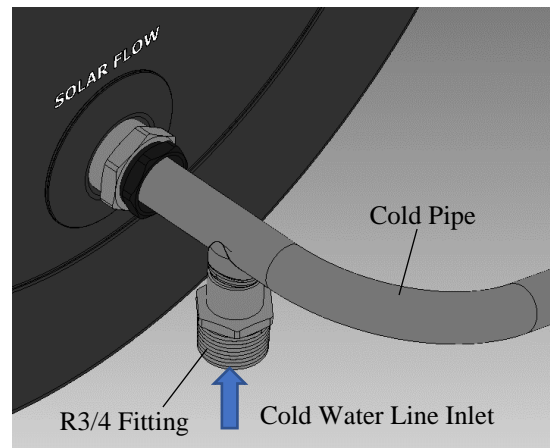

The cold-water supply line to the water heater must be connected to the Male R $\frac{3}{4}$ brass fitting on the cold pipe as shown in the image above. The hexagonal flats of the cold-water inlet fitting must be held by a spanner to prevent the rotation of this fitting when the mating fitting of the cold line is attached to it.

An isolation valve (stop-cock) and non-return valve must be installed on the cold-water line to the water heater. An acceptable arrangement is shown in the diagram.

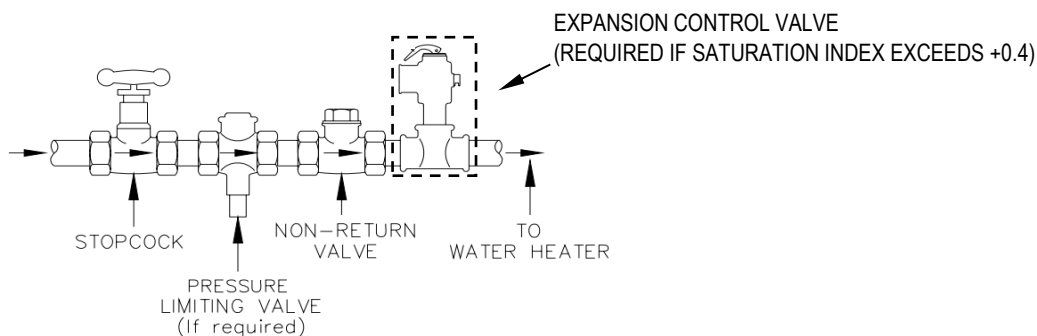

An Expansion Control Valve must be installed if the saturation index of the water supply exceeds +0.4. Refer to Saturation Index on Page 6 for further details including Warranty limitations associated with it. The parts shown in the above image are not supplied in the kit.

TEMPERATURE PRESSURE RELIEF VALVE (UNVENTED SYSTEM)

A TPR valve (Part No. VN0262002K) must be fitted to the tank to limit the tank water pressure to 1,000 kPa and the tank water temperature to 99°C. It is MANDATORY that this TPR valve be fitted in all cases, except where the storage tank is vented to atmosphere through a vent pipe.

The TPR valve must be fitted before the water heater is operated. Before fitting the TPR valve, make sure the probe has not been bent. Seal the thread with a thread sealant such as Teflon tape. Make sure the thread sealant tape does not hang over the end of the thread, ensuring it is at least 3 mm back from the end of the thread to prevent tape fouling the valve seat. Screw the valve into the Pressure Relief Port of the tank. When tightening. When tightening the valve, use the spanner flats provided. Do not use a wrench on the TPR valve body

Continuous leakage of water from the TPR valve or its drain line may indicate a problem with the water heater.

Warning: Never block the outlet of the TPR valve or its drain line for any reason.

RELIEF VALVE DRAIN LINE

A DN15 copper drain line must be fitted to the temperature pressure relief valve. Connect the drain lines to the valves using disconnection unions.

The drain line from the valve to the point of discharge must:

- be as short as possible;
- have a continuous fall all the way from the water heater;
- have no tap, valves or other restrictions; and
- be no longer than 9 m with no more than three bends greater than 45°

Note: The maximum length of 9 m for a drain line is reduced by 1 m for each additional bend of greater than 45°, up to a maximum of three additional bends. Where the distance from the water heater to the final point of discharge exceeds the maximum length, the drain line from the valve may discharge into a tundish.

Do not allow water from the valve outlets or drain pipes to drip or discharge onto roofing materials or roof gutters. These pipes should run to ground level where hot water discharge is safe and clear of any paved areas. Where a drain line crosses over a metal roof, the pipe work must be fully insulated with weatherproof lagging to offer corrosion protection to the metal roof against water runoff over the copper pipe. The insulation must be UV resistant if exposed.

⚠ Warning: As the function of the temperature pressure relief valve is to discharge high temperature water under certain conditions, it is strongly recommended the pipe work downstream of the relief valve be capable of carrying water exceeding 93°C. Failure to observe this precaution may result in damage to pipe work and property.

VENTED SYSTEM CONNECTION

The Vent pipe must be connected to the relief port at the top of the tank. The recommended setup of a vented system is as shown below:

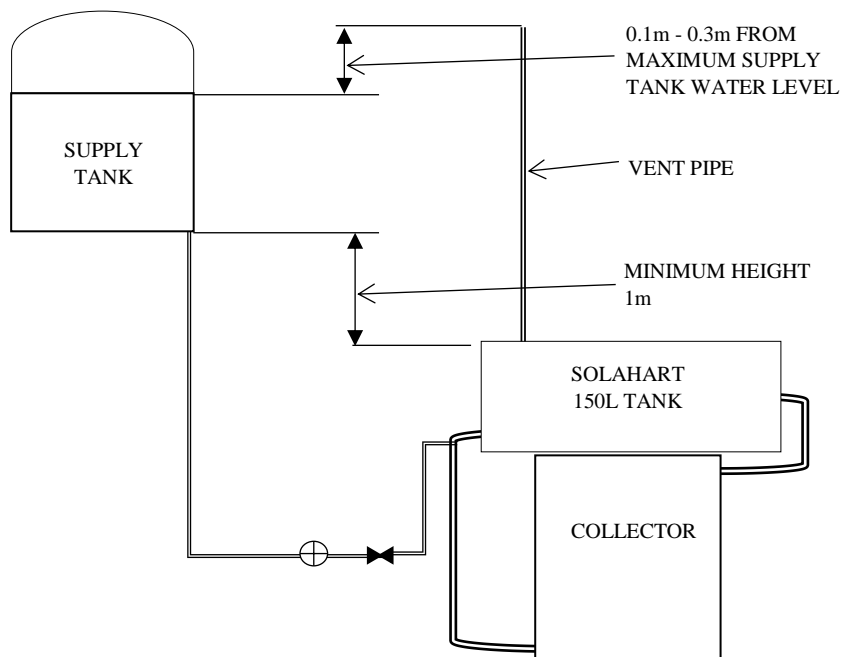

NOTE: A vent pipe cannot be used with a pumped water supply or from a pressurized mains water supply.

The recommended specifications for the vent pipe are:

- Material: Polymeric Tubing or Copper Tubing
- Minimum Internal Diameter 15mm
- Vent pipe should extend to 100mm (0.1m) to 300mm (0.3m) above the water surface of the header tank and must be structurally supported to maintain this height.

HOT WATER OUTLET

The hot water outlet of the water heater is labeled as "HOT OUTLET". This is a Rp3/4 fitting. Connect hot water delivery line to this port.

This water heater can deliver water at temperatures which can cause scalding. We recommend that a tempering valve be fitted to the hot water line to reduce the risk of scalding. Refer to plumbing codes applicable in the area to see if a tempering valve is required for this installation for the supply of hot water from the solar water heater.

EXTERNAL PIPE INSULATION

Solahart recommends:

- That all hot water pipe work should have closed cell insulation of minimum 13mm thickness; this includes tank to collector inter-connecting pipes. Insulation should be suitable for the temperature of operation (i.e. at least 90°C for hot water supply pipes and at least 120°C for tank to collector connections).
- Insulation in external locations should be weatherproof and resistant to UV radiation.
- Insulation will improve system performance and will also protect against burns where the water heater is in a trafficable location.

FILLING AND COMMISSIONING THE STORAGE TANK AND COLLECTORS

⚠ Warning: Do not turn on electric power until after the water heater has been filled with water.

Turn on at least one hot water outlet tap, preferably over a bath or laundry basin. Open the mains water supply valve on the line to the water heater to allow water to fill the storage cylinder and collectors, dispelling air out of the top of the cylinder through the open tap. As soon as water flows freely (without air bursts) from the tap, close the tap and allow the cylinder to pressurize. Check all joints for water tightness.

If fitted gently operate the easing levers on the temperature and pressure relief valve and expansion control valve to ensure that the valves are functional. The system tank is now filled and ready to operate.

If fitted Turn ON the electric power to the heating unit ensuring that the power is correctly connected i.e. 'Active' line to 'Active' terminal etc.

Remove the solar collector packaging. This must be removed completely prior to the permanent operation of the water heater.

Electrical

ELECTRICAL CONNECTION

All electrical work and permanent wiring must be carried out by a qualified person. All installations are to be in accordance with national and local electrical codes and regulatory authority requirements applicable in your area.

⚠ Warning: Do not turn power on until the water heater is filled with water or damage to the heating element will result.

The power rating and current requirement of your Solahart water heater will be specified on the water heater's data plate, located on the cover to the electrical cavity. The temperature rating of the power supply lead's insulation should suit this application. A flexible 20 mm conduit is required for the electrical cable to the solar storage tank. The conduit is to be connected to the unit with a 20 mm terminator. Connect the power supply wires directly to the terminal block and earth tab connection, ensuring there are no excess wire loops inside the control cover.

An isolation switch **MUST** be installed in the meter box for service work on the unit. The isolating switch should be left switched on.

If water and/or power are not available on completion of installation, leave the isolation switch in the meter box in the OFF position and place a warning label "Do not turn on electricity until the water heater is filled with water" on the electrical isolation switch.

⚠ Warning: If the power supply cord to the heater is damaged it must be replaced by a qualified person in order to avoid a hazard.

INSTALLER'S CHECKLIST

- Ensure that the system is installed as directed in this manual
- Ensure the system is installed with the correct TILT (hot pipe side higher)
- Check that all mechanical fixings are secured
- Check that all pipe connections are correctly tightened
- Ensure potable water is connected and switched on
- Check that the potable water tank is filled
- Ensure that electrical power is switched on (if required)
- Ensure the Collector covers are removed
- Ensure that any pipe penetrations through the roof have been sealed correctly
- Ensure roof tiles are put back in to position and roof flashing is watertight
- Householder instructed on water heater system use
- Provide this manual to the householder

SERVICING

To Empty the Water Heater

 **Warning:** The water supply to the system should not be switched off until the collectors are securely covered by an opaque material.

- 1) Turn off the electricity supply.
- 2) Flush cold water through the tank to cool the tank and turn off water supply.
- 3) Release the water pressure at the temperature pressure relief valve by holding the lever open.
- 4) Disconnect the cold water inlet and allow the water to drain out via a hose fitted to the cold water inlet connection.
- 5) Avoid contact with the hot water and ensure that the hose safely discharges hot water away from the roof area.
- 6) Hold open the TPR valve lever to allow air into the storage tank.

Anode Replacement

To replace the anode:

- 1) Turn off the electricity supply and water supply.
- 2) Release the water pressure at the temperature pressure relief valve by holding the lever open.
- 3) Drain the cylinder to a level below the anode fitting (see “[To Empty the Water Heater](#)” above).
- 4) Remove the center cap on the side of the tank where the Hot Water outlet is located to uncover the anode nut. Unscrew the anode nut and withdraw the old anode.
- 5) Insert the new anode assembly into the cylinder through the anode socket. Tighten the new anode nut. Plug back the center cap
- 6) Turn on the water supply, dispel air from the tank via a hot water tap or the temperature pressure relief valve and then check that the seal on the nut is watertight.
- 7) Re-fit the cover and turn on the electricity supply.

 **Warning:** Do not turn power on until the water heater is filled with water or damage to the heating element will result.

Troubleshooting – Save A Service Call

Should your Solahart not provide hot water please check the following before requesting a service call:

- 1) Shading from trees is not excessive and is not covering the collectors for all or part of the day.
- 2) Hot water usage is not excessive.
- 3) Hot water is not leaking from within the plumbing system.
- 4) Electrical heating unit switch and/or time switch is turned ON.
- 5) Electrical heating unit circuit fuse or circuit breaker is sound.
- 6) Electric meter speeds up when the heating unit switch is turned ON after being OFF.

Contact your local Solahart Dealer if all of the above have been checked and there is still no hot water.

Solahart Thermosiphon Solar Water Heater Warranty

1. THE SOLAHART WARRANTY – GENERAL

- 1.1 This warranty is given by Solahart Industries Pty Limited ABN 45 064 945 848 of 1 Alan Street, Rydalmere New South Wales.
- 1.2 Solahart offers service through its Distributor network. Solahart will repair or replace components at the address of the water heater subject to the terms of the Solahart warranty. Solahart, in addition can provide preventative maintenance and advice on the operation of your water heater.
- 1.3 For details about this warranty contact your local Solahart Distributor.
- 1.4 The terms of this warranty and what is covered by it are set out in sections 2 and 3 and apply to water heaters manufactured after 1st January 2019.
- 1.5 If a subsequent version of this warranty is published, the terms of that warranty and what is covered by it will apply to water heaters manufactured after the date specified in the subsequent version.

2. TERMS OF THE SOLAHART WARRANTY AND EXCLUSIONS TO IT

- 2.1 The decision of whether to repair or replace a faulty component is at Solahart's sole discretion.
- 2.2 If you require a call out and we find that the fault is not covered by the Solahart warranty, you are responsible for our standard call out charge. If you wish to have the relevant component repaired or replaced by Solahart that service will be at your cost.
- 2.3 Where a failed component or cylinder is replaced under this warranty, the balance of the original warranty period will remain effective. The replacement does not carry a new Solahart warranty.
- 2.4 Where the water heater is installed outside the boundaries of a metropolitan area as defined by Solahart or further than 30 km from a regional Solahart Distributor, the cost of transport, insurance and travelling between the nearest Solahart Distributor's premises and the installed site shall be the owner's responsibility.
- 2.5 Where the water heater is installed in a position that does not allow safe or ready access, the cost of that access, including the cost of additional materials handling and/or safety equipment, shall be the owner's responsibility. In other words, the cost of dismantling or removing cupboards, doors or walls and the cost of any special equipment to bring the water heater to floor or ground level or to a serviceable position is not covered by this warranty.
- 2.6 This warranty only applies to the original and genuine Solahart water heater in its original installed location and any genuine Solahart replacement parts.
- 2.7 The Solahart warranty does not cover faults that are a result of:
 - a) Accidental damage to the water heater or any component (for example: (i) Acts of God such as floods, storms, fires, lightning strikes and the like; and (ii) third party acts or omissions).
 - b) Misuse or abnormal use of the water heater.
 - c) Installation not in accordance with the Owner's Guide and Installation Instructions or with relevant statutory and local requirements in the State or Territory in which the water heater is installed.
 - d) Connection at any time to a water supply that does not comply with the water supply guidelines as outlined in the Owner's Guide and Installation Instructions.
 - e) Repairs, attempts to repair or modifications to the water heater by a person other than the Solahart Distributor.
 - f) Faulty plumbing or faulty gas or power supply.
 - g) Failure to maintain the water heater in accordance with the Owner's Guide and Installation Instructions.
 - h) Transport damage.
 - i) Fair wear and tear from adverse conditions (for example, corrosion).
 - j) Cosmetic defects.
 - k) Breakage of collector glass for any reason including hail damage (we suggest that the collector glass be covered by your home insurance policy).
 - l) Ice formation in the waterways of a direct open circuit thermosiphon system or an indirect closed circuit thermosiphon system due to non Solahart approved or incorrectly mixed closed circuit fluid being used.
 - m) Non Solahart approved or incorrectly mixed closed circuit fluid being used or incorrect or insufficient filling of the closed circuit system with the closed circuit fluid.
- 2.8 Subject to any statutory provisions to the contrary, this warranty excludes any and all claims for damage to furniture, carpet, walls, foundations or any other consequential loss either directly or indirectly due to leakage from the water heater, or due to leakage from fittings and/ or pipe work of metal, plastic or other materials caused by water temperature, workmanship or other modes of failure.
- 2.9 The Solahart warranty applies to a Solahart thermosiphon solar water heater installed in either a "single-family domestic dwelling".

SOLAHART THERMOSIPHON SOLAR WATER HEATER WARRANTY

3. WHAT IS COVERED BY THE SOLAHART WARRANTY FOR THE WATER HEATERS DETAILED IN THIS DOCUMENT

3.1 Solahart will repair or replace a faulty component of your water heater if it fails to operate in accordance with its specifications as follows:

What components are covered	The period from the date of installation in which the fault must appear in order to be covered	What coverage you receive
Sunny Systems (from date of installation)		
All components	Year 1	Repair and/or replacement of the faulty component, free of charge, including labour.
The cylinder and solar collector(s) (only if a tank, collector(s) and components are purchased and installed as a complete new Solahart system)	Years 2 to 5	Replacement cylinder or solar collector, free of charge. Installation and repair labour costs are the responsibility of the owner.

4. ENTITLEMENT TO MAKE A CLAIM UNDER THIS WARRANTY

4.1 To be entitled to make a claim under this warranty you need to:

- a) Be the owner of the water heater or have consent of the owner to act on their behalf.
- b) Contact Solahart without undue delay after detection of the defect and, in any event, within the applicable warranty period.

4.2 You are not entitled to make a claim under this warranty if your water heater:

- a) Does not have its original serial numbers or rating labels.

5. HOW TO MAKE A CLAIM UNDER THIS WARRANTY

5.1 If you wish to make a claim under this warranty, you need to:

- a) Contact your local Solahart Distributor.
- b) Solahart will arrange for the water heater to be tested and assessed on-site.
- c) If Solahart determines that you have a valid warranty claim, Solahart will repair or replace the water heater in accordance with this warranty.

5.2 Any expenses incurred in the making of a claim under this warranty will be borne by you.

AFFIX INSTALLATION AND WARRANTY REPORT HERE

Note: Installation and Warranty report to be produced in quadruplicate
on carbon copy paper in the colours indicated

Solahart Industries Pty Ltd
(ABN 45 064 945 848)

Principal Manufacturing Facility
55 Brodie Street
Rydalme, New South Wales, 2116
Australia

Postal Address:
PO Box 7508
Silverwater NSW 2128
Australia

www.solahart.com.au

Registered Office
1 Alan Street
Rydalme New South Wales 2116
Australia

International Sales

Telephone International Sales: + 61 8 9351 4600

Email: solahart@solahart.com.au

Web: www.solahart.com

Item No VN0930027 Revision 3
April 2020